

Axial piston variable pump (A)A10VSO series 31

Americas

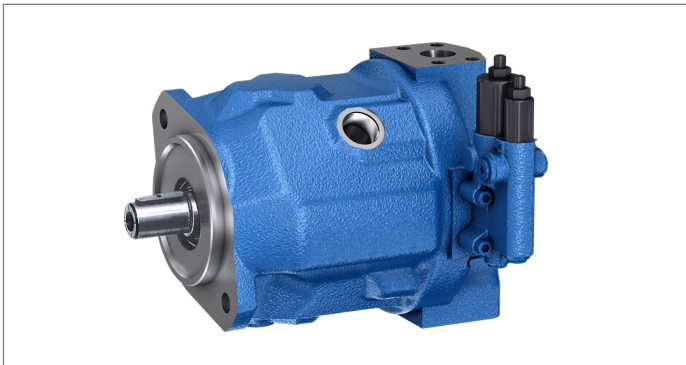

► For **size 140** please refer to data sheet 92714

- All-purpose medium pressure pump
- Sizes 18 to 100
- Nominal pressure 4100 psi (280 bar)
- Maximum pressure 5100 psi (350 bar)
- Open circuit

Features

- Variable pump with axial piston rotary group in swashplate design for hydrostatic drives in open circuit.
- Flow is proportional to drive speed and displacement.
- The flow can be infinitely varied by adjusting the swashplate.
- 2 drain ports
- Excellent suction characteristics
- Low noise level
- Long service life
- Good power to weight ratio
- Versatile controller range
- Short control time
- The through drive is suitable for adding gear pumps and axial piston pumps up to the same size, i.e., 100% through drive.
- Suitable for operation with mineral oil and HF hydraulic fluids

Contents

Type code	2
Hydraulic fluids	4
Working pressure range	6
Technical data, standard unit	8
Technical data, high-speed version	9
Technical data, HF hydraulic fluids	10
Permissible radial and axial loading of the drive shaft	11
DG – Two-point control, direct operated	13
DR – Pressure controller	14
DRG – Pressure controller, remotely controlled	15
DFR/DFR1 – Pressure flow controller	16
DFLR – Pressure, flow and power controller	18
ED – Electro-hydraulic pressure control	19
ER – Electro-hydraulic pressure control	21
Dimensions, size 18 to 100	22
Dimensions, through drive	37
Overview of mounting options	40
Combination pumps (A)A10VSO + (A)A10VSO	41
Connector for solenoids	42
Control electronics	42
Installation instructions	43
Project planning notes	46
Safety instructions	47

Type code

01	02	03	04	05	06	07	08	09	10	11	12	13
	(A)A10VS	O			/	31		-		C		

Version		18	28	45	71	88	100	
01	Standard version for mineral oil (without code)	●	●	●	●	●	●	
	HFA, HFB, HFC hydraulic fluid	●	●	●	●	●	●	E
	High-speed version (external dimensions are not affected by this option).	-	-	●	●	-	●	H

Axial piston unit		18	28	45	71	88	100	
02	Swashplate design, variable, nominal pressure 4100 psi (280 bar), maximum pressure 5100 psi (350 bar)	●	-	-	-	-	-	A10VS
		-	●	●	●	●	●	AA10VS

Operating mode		
03	Pump, open circuit	O

Size (NG)		18	28	45	71	88	100
04	Geometric displacement, see table of values on page 8 and 9						

Control device		18	28	45	71	88	100	
05	Two-point control, direct operated	●	●	●	●	●	●	DG
	Pressure controller hydraulic	●	●	●	●	●	●	DR
	with flow controller hydraulic X-T open	●	●	●	●	●	●	DFR
	X-T plugged, with flushing function	●	●	●	●	●	●	DFR1
	with pressure cut-off hydraulic remote controlled	●	●	●	●	●	●	DRG
	electric negative control U = 24 V	●	●	●	●	●	●	ED72
	electric positive control U = 24 V	●	●	●	●	●	●	ER72
	Pressure, flow and power controller	-	●	●	●	●	●	DFLR

Series		
06	Series 3, index 1	31

Direction of rotation		18	28	45	71	88	100	
07	Viewed on drive shaft clockwise	●	●	●	●	●	●	R
	counter-clockwise	●	●	●	●	●	●	L

Sealing material		18	28	45	71	88	100	
08	FKM (fluorocarbon rubber)	●	●	●	●	●	●	V
	NBR (nitrile rubber) only with use of HFA, HFB, HFC hydraulic fluid (position 01; order code "E")	●	●	●	●	●	●	P

Drive shaft		18	28	45	71	88	100	
09	Splined shaft standard shaft	●	●	●	●	●	●	S
	ISO 3019-1 similar to shaft "S" however for higher torque	●	●	●	●	●	-	R
	reduced diameter, not for through drive	●	-	-	-	-	●	U
	Parallel keyed shaft permissible through-drive torque (see page 11)	●	●	●	●	●	●	K
	ISO 3019-1							

01	02	03	04	05	06	07	08	09	10	11	12	13
	(A)A10VS	O			/	31		-		C		

Mounting flange										18	28	45	71	88	100		
10	ISO 3019-1					2-hole					●	●	●	●	●	●	C

Working port										18	28	45	71	88	100		
11	SAE flange connections according to ISO 6162 fastening thread, UNC					laterally opposite					●	●	●	-	-	●	62
											-	-	-	●	●	-	92

Through drive (for mounting options, see page 40)

12	For flange ISO 3019-1					Hub for splined shaft ¹⁾													
	Diameter					Diameter					18	28	45	71	88	100			
	without through drive												●	●	●	●	●	●	N00
	82-2 (A)		5/8 in		9T 16/32DP			●	●	●	●	●	●	●	K01				
			3/4 in		11T 16/32DP			●	●	●	●	●	●	●	K52				
	101-2 (B)		7/8 in		13T 16/32DP			-	●	●	●	●	●	K68					
			1 in		15T 16/32DP			-	-	●	●	●	●	K04					
	127-2 (C)		1 1/4 in		14T 12/24DP			-	-	-	●	●	●	K07					
			1 1/2 in		17T 12/24DP			-	-	-	-	-	●	K24					

Connector for solenoids²⁾										18	28	45	71	88	100		
13	Without connector (without solenoid, only for hydraulic controls, without code)										●	●	●	●	●	●	
	HIRSCHMANN connector – without suppressor diode										●	●	●	●	●	●	H

● = Available ○ = On request - = Not available

Notice

- ▶ Observe the project planning notes on page 46 and the project planning notes regarding each control device.
- ▶ In addition to the type code, please specify the relevant technical data when placing your order.

1) Hub for splined shaft according to ANSI B92.1a (drive shaft allocation according to ISO 3019-1)
2) Connectors for other electric components can deviate.

Hydraulic fluids

The (A)A10VSO variable pump is designed for operation with HLP mineral oil according to DIN 51524-2.

See the following data sheets for application instructions and requirements for hydraulic fluids before the start of project planning:

- ▶ 90220: Hydraulic fluids based on mineral oils and related hydrocarbons
- ▶ 90221: Environmentally acceptable hydraulic fluids
- ▶ 90222: Fire-resistant, water-free hydraulic fluids (HFDR/HFDU) (for permissible technical data, see data sheet 90225)
- ▶ 90223: Fire-resistant, water-containing hydraulic fluids (HFAE, HFAS, HFB, HFC)
- ▶ 90225: Limited technical data for operation with water-free and water-containing fire-resistant hydraulic fluids (HFDR, HFDU, HFB, HFC) – technical data

Viscosity and temperature of hydraulic fluids

	Viscosity	Shaft seal	Temperature ²⁾	Remarks
Cold start	$v_{\max} \leq 1600$ cSt (mm ² /s)	FKM	$\vartheta_{\text{St}} \geq -13$ °F (-25 °C)	$t \leq 3$ min, without load ($p \leq 725$ psi (50 bar)), $n \leq 1000$ rpm. Permissible temperature difference between axial piston unit and hydraulic fluid in the system maximum 45 °F (25 K)
Warm-up phase	$v = 1600 \dots 400$ cSt (mm ² /s)			$t \leq 15$ min, $p \leq 0.7 \times p_{\text{nom}}$ and $n \leq 0.5 \times n_{\text{nom}}$
Continuous operation	$v = 400 \dots 10$ cSt (mm ² /s) ¹⁾	FKM	$\vartheta \leq +230$ °F (+110°C)	Measured at port L , L₁
	$v_{\text{opt}} = 36 \dots 16$ cSt (mm ² /s)			Optimal operating viscosity and efficiency range
Short-term operation	$v_{\min} = 10 \dots 7$ cSt (mm ² /s)	FKM	$\vartheta \leq +230$ °F (+110°C)	$t \leq 3$ min, $p \leq 0.3 \times p_{\text{nom}}$, measured at port L , L₁

Selection diagram

Maximum permissible viscosity on cold start

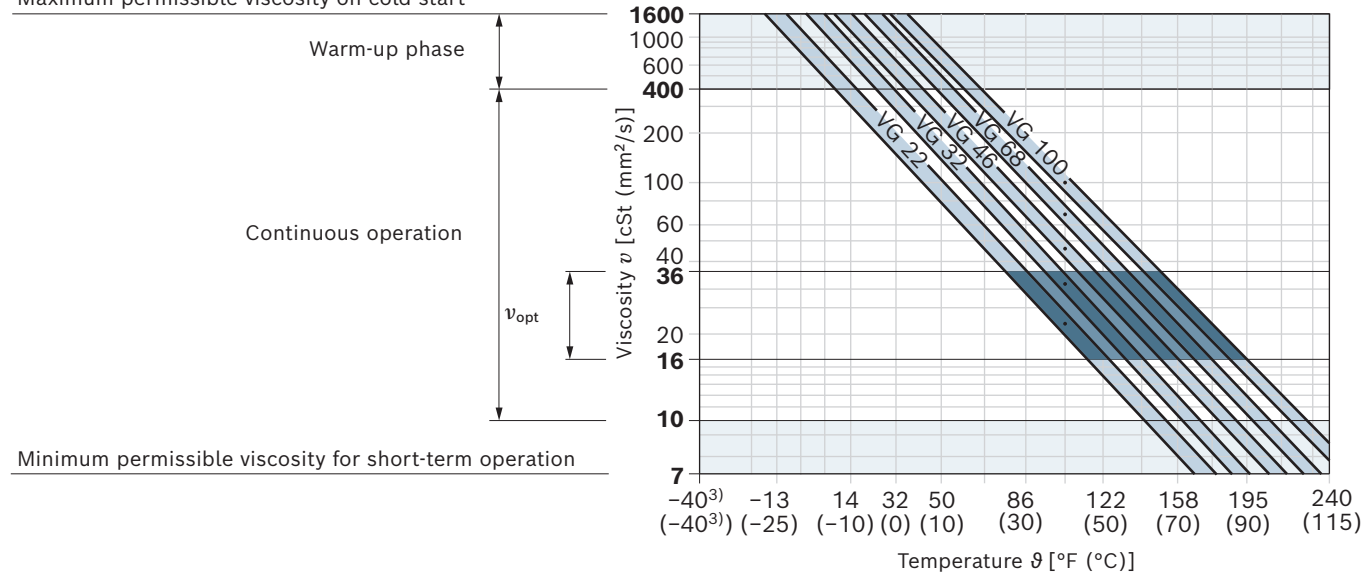

1) This corresponds, for example on the VG 46, to a temperature range of +4 °C to +85 °C (see selection diagram)
2) If the temperature at extreme operating parameters cannot be adhered to, please contact us.

Selection of hydraulic fluid

Bosch Rexroth evaluates hydraulic fluids on the basis of the Fluid Rating according to the technical data sheet 90235.

Hydraulic fluids with positive evaluation in the Fluid Rating are provided in the following technical data sheet:

- ▶ 90245: Bosch Rexroth Fluid Rating List for Rexroth hydraulic components (pumps and motors)

Selection of hydraulic fluid shall make sure that the operating viscosity in the operating temperature range is within the optimum range (v_{opt} ; see selection diagram).

Notice

- ▶ The axial piston unit is suitable for operation with water-containing HF hydraulic fluid. See version "E"

Filtration of the hydraulic fluid

Finer filtration improves the cleanliness level of the hydraulic fluid, which increases the service life of the axial piston unit.

A cleanliness level of at least 20/18/15 is to be maintained according to ISO 4406

At a hydraulic fluid viscosity of less than 10 cSt (mm²/s) (e.g. due to high temperatures during short-term operation), at the drain port, a cleanliness level of at least 19/17/14 under ISO 4406 is required.

For example, viscosity corresponds to 10 cSt (mm²/s) at:

- HLP 32 a temperature of 163 °F (73 °C)
- HLP 46 a temperature of 185°F (85 °C)

Working pressure range

Pressure at working port B		Definition
Nominal pressure p_{nom}	4100 psi (280 bar)	The nominal pressure corresponds to the maximum design pressure.
Maximum pressure p_{max}	5100 psi (350 bar)	The maximum pressure corresponds to the maximum working pressure within a single operating period. The sum of single operating periods must not exceed the total operating period.
Single operating period	2 ms	
Total operating period	300 h	
Minimum pressure $p_{B absolute}$ (high-pressure side)	145 psi (10 bar) ¹⁾	Minimum pressure on the high-pressure side (B) which is required in order to prevent damage to the axial piston unit.
Rate of pressure change $R_{A max}$	232060 psi/s (16000 bar/s)	Maximum permissible pressure build-up and reduction speed during a pressure change across the entire pressure range.
Pressure at suction port S (inlet)		
Minimum pressure $p_{S min}$ Standard	12 psi (0.8 bar) absolute	Minimum pressure at suction port S (inlet) which is required to prevent damage to the axial piston unit. The minimum pressure depends on the rotational speed and displacement of the axial piston unit.
Maximum pressure $p_{S max}$	145 psi (10 bar)	
Case pressure at port L, L ₁		
Maximum pressure $p_{L max}$	30 psi (2 bar) ¹⁾ absolute	Maximum 7.5 psi (0.5 bar) higher than inlet pressure at port S, but not higher than $p_{L max}$. A drain line to the reservoir is required.
Pilot pressure port X with external high pressure		
Maximum pressure p_{max}	5100 psi (350 bar)	When designing all control lines with external high pressure, the values for the rate of pressure change, maximum single operating period and total operating period applicable to port B must not be exceeded.

▼ Rate of pressure change $R_{A max}$

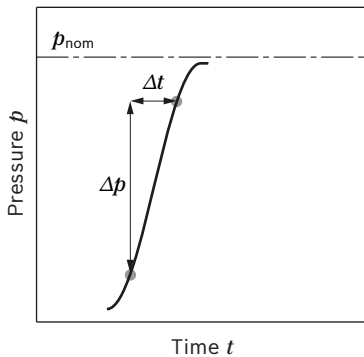

Notice

- ▶ Working pressure range applies when using hydraulic fluids based on mineral oils. Please contact us for values for other hydraulic fluids.
- ▶ In addition to the hydraulic fluid and the temperature, the service life of the shaft seal is influenced by the rotational speed of the axial piston unit and the case pressure.
- ▶ The case pressure must be greater than the external pressure (ambient pressure) at the shaft seal.

▼ Pressure definition

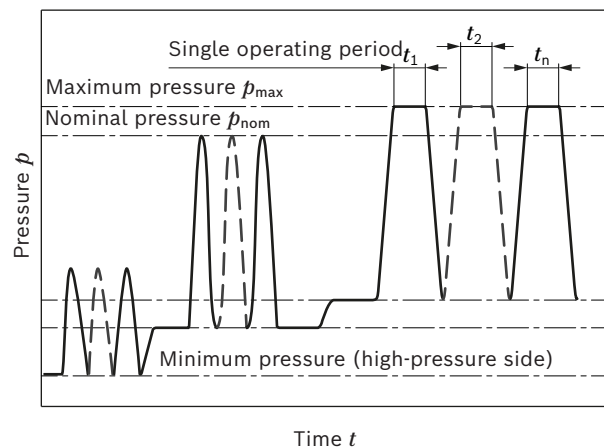

$$\text{Total operating period} = t_1 + t_2 + \dots + t_n$$

1) Other values on request

Minimum permissible inlet pressure at suction port S with speed increase

In order to avoid damage to the pump (cavitation), a minimum inlet pressure must be guaranteed at suction port **S**. The minimum inlet pressure level depends on the rotational speed and the displacement of the variable pump.

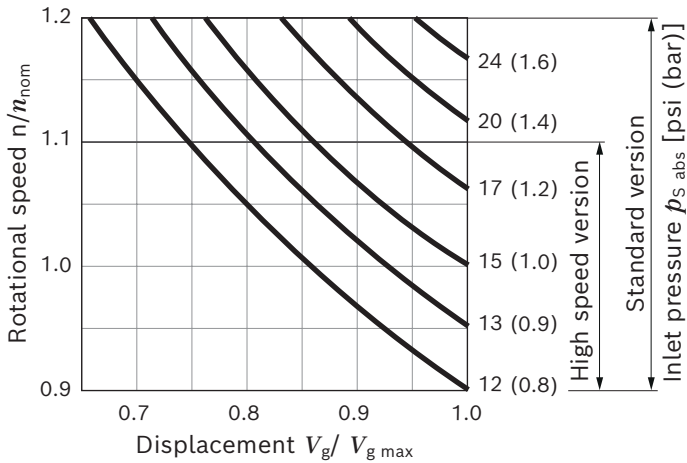

During continuous operation in overspeed over n_{nom} , a reduction in operational service life is to be expected due to cavitation erosion.

Technical data, standard unit

Size	NG	18	28	45	71	88	100		
Displacement, geometric, per revolution	$V_{g \max}$	in ³ (cm ³)	1.10 (18)	1.71 (28)	2.75 (45)	4.33 (71)	5.37 (88)	6.10 (100)	
Rotational speed maximum ¹⁾	at $V_{g \max}$	n_{nom}	rpm	3300	3000	2600	2200	2100	2000
	at $V_g < V_{g \max}^{2)}$	$n_{\text{max perm}}$	rpm	3900	3600	3100	2600	2500	2400
Flow	at n_{nom} and $V_{g \max}$	$q_{v \max}$	gpm (l/min)	15.6 (59)	22 (84)	30.9 (117)	41.2 (156)	48.9 (185)	52.8 (200)
	at $n_E = 1800$ rpm and $V_{g \max}$	$q_{vE \max}$	gpm (l/min)	8.5 (32)	13.3 (50)	21.4 (81)	33.8 (128)	41.8 (158)	47.6 (180)
Power	at n_{nom} , $V_{g \max}$	P_{max}	HP (kW)	38 (28)	52 (39)	74 (55)	98 (73)	115 (86)	125 (93)
	at $\Delta p = 4100$ psi (280 bar)	at $n_E = 1800$ rpm and $V_{g \max}$	$P_{E \max}$	HP (kW)	19 (15)	31 (24)	50 (38)	79 (69)	99 (74)
Torque	$\Delta p = 4100$ psi (280 bar)	M_{max}	lb-ft (Nm)	59 (80)	92 (125)	148 (200)	233 (316)	289 (392)	328 (445)
	at $V_{g \max}$ and $\Delta p = 1450$ psi (100 bar)	M	lb-ft (Nm)	22 (30)	33 (45)	53 (72)	83 (113)	103 (140)	117 (159)
Rotary stiffness of drive shaft	S	c	lb-ft/rad (Nm/rad)	8177 (11087)	16460 (22317)	27659 (37500)	53019 (71884)	53019 (71884)	89350 (121142)
			R	c	lb-ft/rad (Nm/rad)	10953 (14850)	19442 (26360)	30258 (41025)	56457 (76545)
	U	c	lb-ft/rad (Nm/rad)	5967 (8090)	– –	– –	– –	– –	67187 (91093)
			K	c	lb-ft/rad (Nm/rad)	9839 (13340)	19316 (26189)	32382 (43905)	60562 (82112)
Moment of inertia for rotary group	J_{TW}	lbs-ft ² (kgm ²)	0.022 (0.00093)	0.040 (0.0017)	0.078 (0.0033)	0.197 (0.0083)	0.197 (0.0083)	0.396 (0.0167)	
Case volume	V	gal (l)	0.106 (0.4)	0.185 (0.7)	0.264 (1.0)	0.420 (1.6)	0.420 (1.6)	0.580 (2.2)	
		Weight without through drive (approx.)	m	lbs (kg)	28 (12.9)	40 (18)	52 (23.5)	78 (35.2)	78 (35.2)
Weight with through drive (approx.)	m	lbs (kg)	31 (14)	43 (19.3)	55 (25.1)	84 (38)	84 (38)	122 (55.4)	

Notice

- ▶ Theoretical values, without efficiency and tolerances; values rounded
- ▶ Operation above the maximum values or below the minimum values may result in a loss of function, a reduced service life or in the destruction of the axial piston unit. Bosch Rexroth recommends checking the loading by means of test or calculation / simulation and comparison with the permissible values.

- The values are applicable:
 - At an abs. pressure $p_{\text{abs}} = 15$ psi (1 bar) at the suction port **S**
 - for the optimum viscosity range from $\nu_{\text{opt}} = 36$ to 16 cSt (mm²/s)
 - with hydraulic fluid based on mineral oils
- For a speed increase up to $n_{\text{max perm}}$, please observe the diagram on page 7.

Determination of the characteristics

Flow	$q_v = \frac{V_g \times n \times \eta_v}{231 (1000)}$	[gpm (l/min)]
Torque	$M = \frac{V_g \times \Delta p}{24 (20) \times \pi \times \eta_{hm}}$	[lb-ft (Nm)]
Power	$P = \frac{2 \pi \times M \times n}{33000 (60000)} = \frac{q_v \times \Delta p}{1714 (600) \times \eta_t}$	[HP (kW)]

Key

- V_g Displacement per revolution [in³ (cm³)]
- Δp Differential pressure [psi (bar)]
- n Rotational speed [rpm]
- η_v Volumetric efficiency
- η_{hm} Hydraulic-mechanical efficiency
- η_t Total efficiency ($\eta_t = \eta_v \times \eta_{hm}$)

Technical data, high-speed version

(external dimensions correspond to the standard unit)

Size		NG		45	71	100
Displacement, geometric, per revolution		$V_{g \max}$	in ³	2.75	4.33	6.10
			(cm ³)	(45)	(71)	(100)
Rotational speed maximum ¹⁾	at $V_{g \max}$	n_{nom}	rpm	3000	2550	2300
	at $V_g < V_{g \max}$ ²⁾	$n_{\text{max perm}}$	rpm	3300	2800	2500
Flow	at n_{nom} and $V_{g \max}$	$q_{v \max}$	gmp	35.7	47	60.8
			(l/min)	(135)	(178)	(230)
Power	at n_{nom} , $V_{g \max}$ and $\Delta p = 4100$ psi (280 bar)	P_{max}	HP	84	111	143
			(kW)	(63)	(83)	(107)
Torque at $V_{g \max}$ and	$\Delta p = 4100$ psi (280 bar)	M_{max}	lb-ft	148	233	328
			(Nm)	(200)	(316)	(445)
	$\Delta p = 1450$ psi (100 bar)	M	lb-ft	53	83	117
			(Nm)	(72)	(113)	(159)
Rotary stiffness of drive shaft	S	c	lb-ft/rad	27659	53019	89350
			(Nm/rad)	(37500)	(71884)	(121142)
	R	c	lb-ft/rad	30258	56457	–
			(Nm/rad)	(41025)	(76545)	–
U	c	lb-ft/rad	–	–	67187	
		(Nm/rad)	–	–	(91093)	
K	c	lb-ft/rad	32270	60352	99448	
		(Nm/rad)	(43905)	(82112)	(135303)	
Moment of inertia for rotary group		J_{TW}	lb-ft ²	0.078	0.197	0.396
			(kgm ²)	(0.0033)	(0.0083)	(0.0167)
Case volume		V	gal	0.264	0.420	0.580
			(l)	(1.0)	(1.6)	(2.2)
Weight without through drive (approx.)		m	lbs	52	78	109
			(kg)	(23.5)	(35.2)	(49.5)
Weight with through drive (approx.)		m	lbs	55	84	122
			(kg)	(25.1)	(38)	(55.4)

Notice

- ▶ Theoretical values, without efficiency and tolerances; values rounded
- ▶ Operation above the maximum values or below the minimum values may result in a loss of function, a reduced service life or in the destruction of the axial piston unit. Bosch Rexroth recommends checking the loading by means of test or calculation / simulation and comparison with the permissible values.

1) The values are applicable:

- At an abs. pressure $p_{\text{abs}} = 15$ psi (1 bar) at the suction port **S**
- for the optimum viscosity range from $\nu_{\text{opt}} = 36$ to 16 cSt (mm²/s)
- with hydraulic fluid based on mineral oils

2) For a speed increase up to $n_{\text{max perm}}$, please observe the diagram on page 7.

Determination of the characteristics

Flow	$q_v = \frac{V_g \times n \times \eta_v}{231 (1000)}$	[gpm (l/min)]
Torque	$M = \frac{V_g \times \Delta p}{24 (20) \times \pi \times \eta_{\text{mh}}}$	[lb-ft (Nm)]
Power	$P = \frac{2 \pi \times M \times n}{33000 (60000)} = \frac{q_v \times \Delta p}{1714 (600) \times \eta_t}$	[HP (kW)]

Key

- V_g Displacement per revolution [in³ (cm³)]
- Δp Differential pressure [psi (bar)]
- n Rotational speed [rpm]
- η_v Volumetric efficiency
- η_{hm} Hydraulic-mechanical efficiency
- η_t Total efficiency ($\eta_t = \eta_v \times \eta_{\text{hm}}$)

Technical data, HF hydraulic fluids

Maximum rotational speed

Hydraulic fluid ¹⁾	E-version	Size	psi (bar)	NG		18	28	45	71	88	100
HFA		at nominal pressure p_N	2030 (140)	n_{nom}	rpm	2450	2250	1950	1650	1550	1500
		at maximum pressure p_{max}	2350 (160)								
HFB		at nominal pressure p_N	2030 (140)	n_{nom}	rpm	2650	2400	2100	1760	1650	1600
		at maximum pressure p_{max}	2350 (160)								
HFC		at nominal pressure p_N	2540 (175)	n_{nom}	rpm	2650	2400	2100	1760	1650	1600
		at maximum pressure p_{max}	2900 (210)								
Technical data, HFD hydraulic fluids											
HFDR, HFDU polyalkylene glycol		at nominal pressure p_N	4100 (280)	n_{nom}	rpm	2650	2400	2100	1760	1650	1600
		at maximum pressure p_{max}	4100 (280)								
HFDU polyol ester		at nominal pressure p_N	4100 (280)			3300	3000	2600	2200	2100	2000

1) For further information on HF hydraulic fluids, please see data sheets 90223 and 90225

Permissible radial and axial loading of the drive shaft

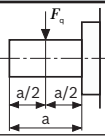
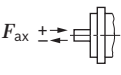
Size		NG	18	28	45	71	88	100	
Maximum radial force at a/2		$F_{q \max}$	lbf	79	270	337	427	42	517
			(N)	(350)	(1200)	(1500)	(1900)	(1900)	(2300)
Maximum axial force		$\pm F_{ax \max}$	lbf	157	225	337	540	540	899
			(N)	(700)	(1000)	(1500)	(2400)	(2400)	(4000)

Notice

- ▶ The values given are maximum values and do not apply to continuous operation. All loads of the drive shaft reduce the bearing service life!
- ▶ For drives with radial loading (pinion, V-belt), please contact us

Permissible inlet and through-drive torques

Size			18	28	45	71	88	100		
Torque at $V_{g \max}$ and $\Delta p = 4100$ psi (280 bar) ¹⁾	M_{max}	lb-ft	59	92	148	232	289	328		
		(Nm)	(80)	(125)	(200)	(316)	(392)	(445)		
Maximum input torque at drive shaft ²⁾	S	$M_{E \max}$	lb-ft	91	145	235	462	462	814	
			(Nm)	(124)	(198)	(319)	(626)	(626)	(1104)	
		DIA	inch	3/4	7/8	1	1 1/4	1 1/4	1 1/2	
	R	$M_{E \max}$	lb-ft	118	184	295	475	475	–	
			(Nm)	(160)	(250)	(400)	(644)	(644)	–	
		DIA	inch	3/4	7/8	1	1 1/4	1 1/4	–	
	U	$M_{E \max}$	lb-ft	43	–	–	–	–	438	
			(Nm)	(59)	–	–	–	–	(595)	
		DIA	inch	5/8	–	–	–	–	1 1/4	
	K	$M_{E \max}$	lb-ft	77	107	156	319	319	553	
			(Nm)	(104)	(145)	(212)	(433)	(433)	(750)	
		DIA	inch	0.7500	0.8750	1.0000	1.2500	1.2500	1.5000	
			(mm)	(19.5)	(22.225)	(25.4)	(31.75)	(31.75)	(38.1)	
	Maximum through-drive torque	S	$M_{D \max}$	lb-ft	80	118	235	363	363	573
				(Nm)	(108)	(160)	(319)	(492)	(492)	(778)
R		$M_{D \max}$	lb-ft	89	130	269	404	404	–	
			(Nm)	(120)	(176)	(365)	(548)	(548)	–	
U		$M_{D \max}$	lb-ft	43	–	–	–	–	438	
			(Nm)	(59)	–	–	–	–	(595)	
K		$M_{D \max}$	lb-ft	77	107	156	319	319	553	
			(Nm)	(104)	(145)	(212)	(433)	(433)	(750)	

1) Efficiency not considered

2) For drive shafts with no radial force

▼ **Distribution of torques**

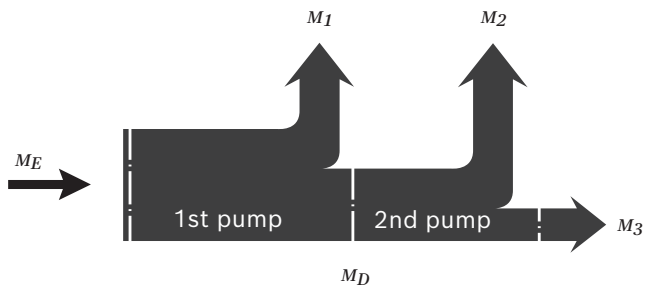

Torque at 1st pump	M_1
Torque at 2nd pump	M_2
Torque at 3rd pump	M_3
Input torque	$M_E = M_1 + M_2 + M_3$
	$M_E < M_{E\ max}$
Through-drive torque	$M_D = M_2 + M_3$
	$M_D < M_{D\ max}$

DG – Two-point control, direct operated

The variable pump can be set to a minimum swivel angle by connecting an external switching pressure to port **X**. This will supply control fluid directly to the stroking piston; a minimum control pressure of $p_{st} \geq 725$ psi (50 bar) is required.

The variable pump can only be switched between $V_{g\ max}$ and $V_{g\ min}$.

Please note that the required switching pressure at port **X** is directly dependent on the actual working pressure p_B in port **B**. (see switching pressure characteristic curve).

The maximum permissible switching pressure is 4100 psi (280 bar).

- ▶ Switching pressure p_{st} in **X** = 0 psi (0 bar) $\triangleq V_{g\ max}$
- ▶ Switching pressure p_{st} in **X** ≥ 725 psi (50 bar) $\triangleq V_{g\ min}$

▼ Switching pressure characteristic curve

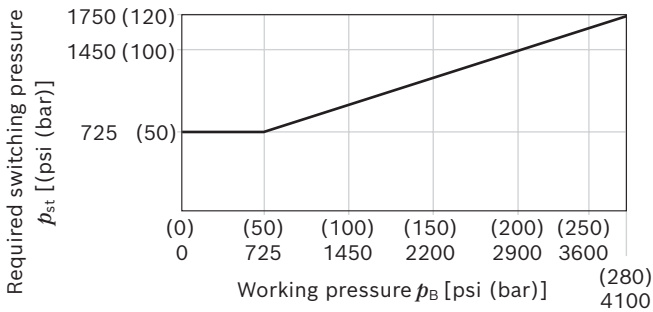

▼ Circuit diagram DG

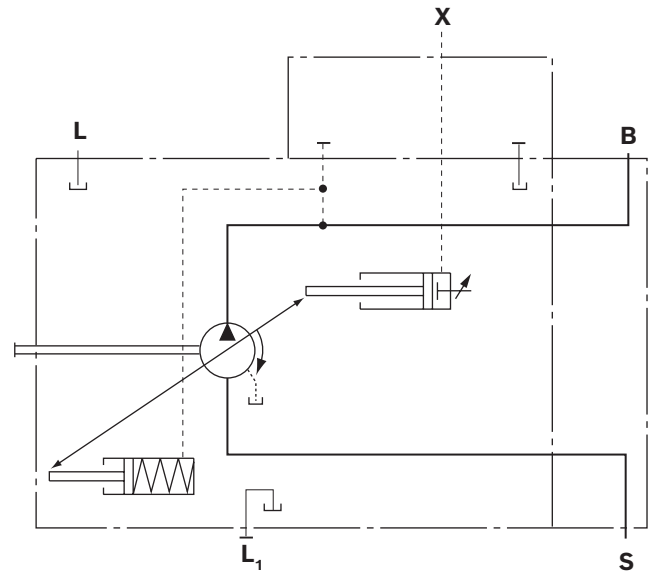

DR – Pressure controller

The pressure controller limits the maximum pressure at the pump outlet within the control range of the variable pump. The variable pump only supplies as much hydraulic fluid as is required by the consumers. If the working pressure exceeds the pressure command value at the pressure valve, the pump will regulate to a smaller displacement to reduce the control differential.

- ▶ Basic position in depressurized state: $V_{g \max}$.
- ▶ Setting range¹⁾ for pressure control 725 to 4100 psi (50 to 280 bar).
Standard is 4100 psi (280 bar).

▼ Characteristic curve

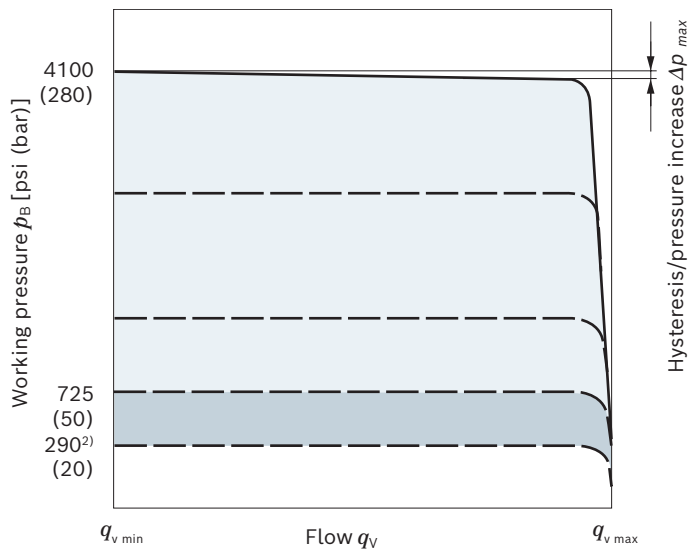

Characteristic curve valid at $n_1 = 1500$ rpm and $\vartheta_{\text{fluid}} = 122$ °F (50 °C).

▼ Circuit diagram DR

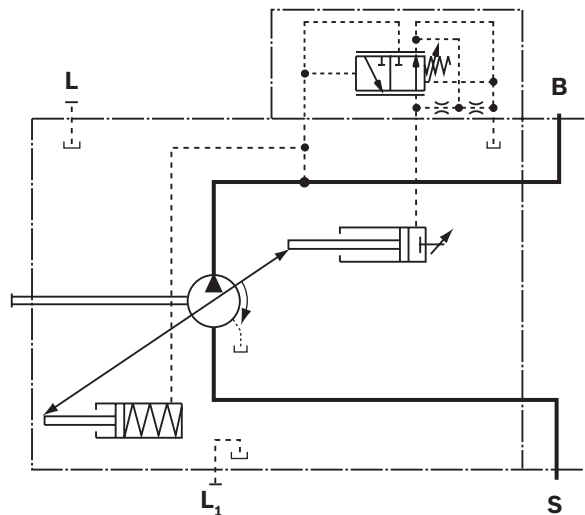

Controller data DR

NG		18	28	45	71	88	100
Pressure increase	Δp [psi (bar)]	60 (4)	60 (4)	87 (6)	115 (8)	130 (9)	145 (10)
Hysteresis and repeatability	Δp [psi (bar)]	maximum 45 (3)					
Pilot fluid consumption	[gpm (l/min)]	maximum approx. 0.8 (3)					

- 1) In order to prevent damage to the pump and the system, the permissible setting range must not be exceeded. The range of possible settings at the valve is higher.
- 2) For settings below 725 psi (50 bar), please use the SO275 special pressure controller (setting range: 290 to 1450 psi (20 to 100 bar)).

DRG – Pressure controller, remotely controlled

For the remote controlled pressure controller, the pressure limitation is performed using a separately arranged pressure relief valve. Therefore, any pressure control value under the pressure set on the pressure controller can be regulated. Pressure controller DR see page 14.

A pressure relief valve is externally piped up to port **X** for remote control. This relief valve is not included in the scope of delivery of the DRG control.

A differential pressure of 290 psi (20 bar) Δp (standard setting) results in a pilot oil flow of approx. 0.4 gpm (1.5 l/min) at port **X**. If another setting is required (range from 145 to 320 psi (10 to 22 bar)) please state in plain text.

As a separate pressure relief valve (**1**) we recommend:

- ▶ A direct operated, hydraulic or electric proportional one, suitable for the quantity of pilot fluid mentioned above.

The maximum line length should not exceed 2 m.

- ▶ Basic position in depressurized state: $V_{g \max}$.
- ▶ Setting range¹⁾ for pressure control 725 to 4100 psi (50 to 280 bar) (**3**).
Standard is 4100 psi (280 bar).
- ▶ Setting range for differential pressure 145 to 320 psi (10 to 22 bar) (**2**).
Standard is 290 psi (20 bar).

Unloading port **X** to the reservoir results in a zero stroke pressure (standby) which is approx. 15 to 30 psi (1 to 2 bar) higher than the defined differential pressure Δp , however system influences are not taken into account.

▼ Characteristic curve of the DRG

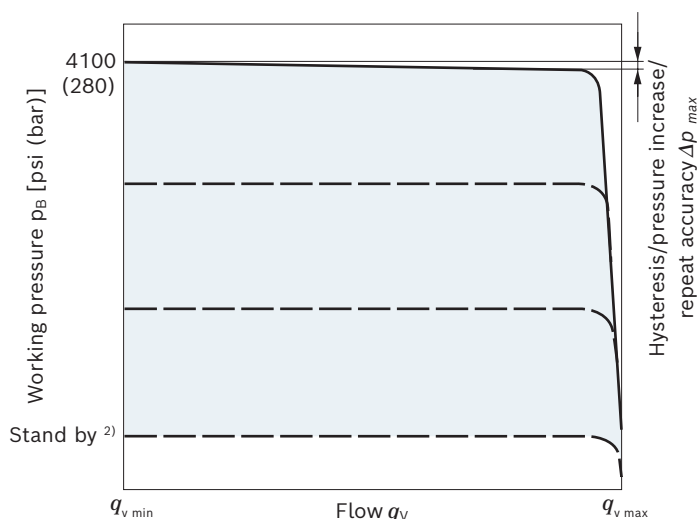

Characteristic curve valid at $n_1 = 1500$ rpm and $\vartheta_{\text{fluid}} = 122$ °F (50 °C).

▼ Circuit diagram of the DRG

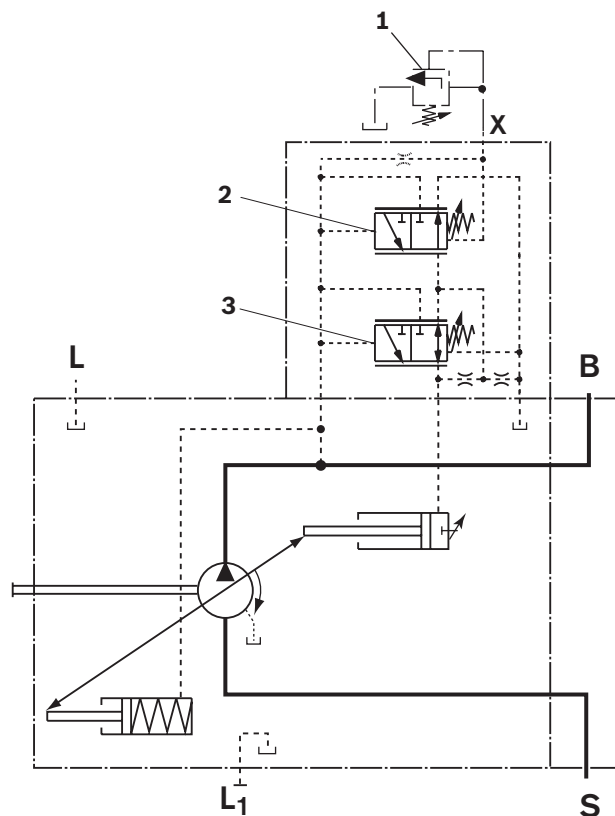

- 1 The separate pressure relief valve and the line are not included in the scope of delivery.
- 2 Remote controlled pressure cut-off (**G**)
- 3 Pressure controller (**DR**)

Controller data DRG

NG		18	28	45	71	88	100
Pressure increase	Δp [psi (bar)]	60 (4)	60 (4)	87 (6)	115 (8)	130 (9)	145 (10)
Hysteresis and repeatability	Δp [psi (bar)]	maximum 60 (4)					
Pilot fluid consumption DR and DRG	[gpm (l/min)]	maximum approx. 1.2 (4.5)					

1) In order to prevent damage to the pump and the system, the permissible setting range must not be exceeded.

The range of possible settings at the valve is higher.

2) Zero stroke pressure from pressure setting Δp on controller (**2**)

DFR/DFR1 – Pressure flow controller

In addition to the pressure controller function (see page 14), an adjustable orifice (e.g. directional valve) is used to adjust the differential pressure upstream and downstream of the orifice. This is used to control the pump flow. The pump flow is equal to the actual hydraulic fluid quantity required by the consumer. With all controller combinations, the V_g reduction has priority.

- ▶ Basic position in depressurized state: $V_{g \max}$.
- ▶ Setting range¹⁾ to 4100 psi (280 bar)
Standard is 4100 psi (280 bar).
- ▶ For pressure controller data, see page 14

Notice

- ▶ The DFR1 version has no unloading between **X** and the reservoir. The LS must thus be unloaded in the system. Because of the flushing function of the flow controller in the DFR1 control valve, sufficient unloading of the **X**-line must also be provided.

▼ Characteristic curve

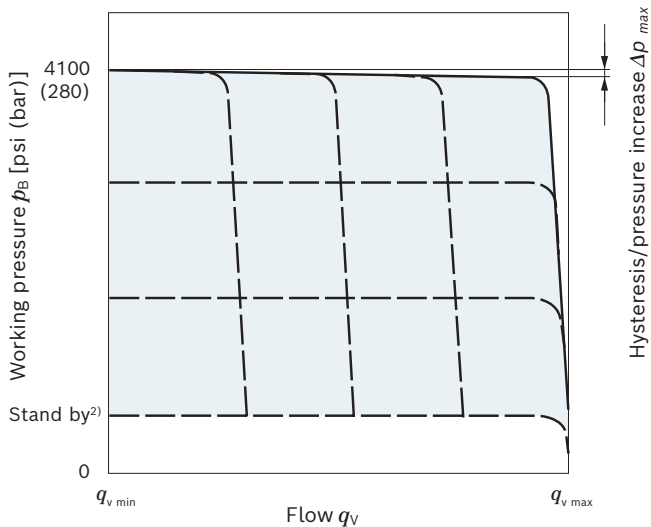

▼ Characteristic curve at variable rotational speed

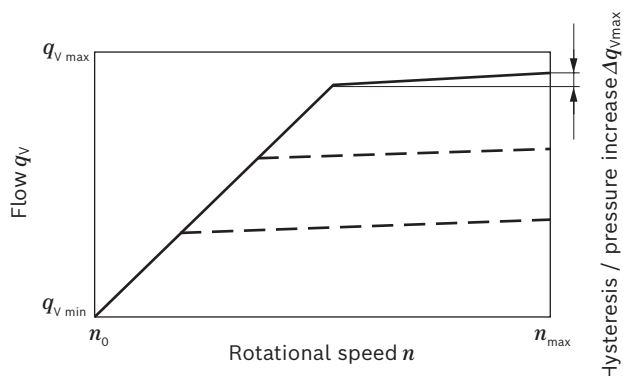

Characteristic curves valid at $n_1 = 1500$ rpm and $\vartheta_{\text{fluid}} = 122$ °F (50 °C).

▼ Circuit diagram DFR

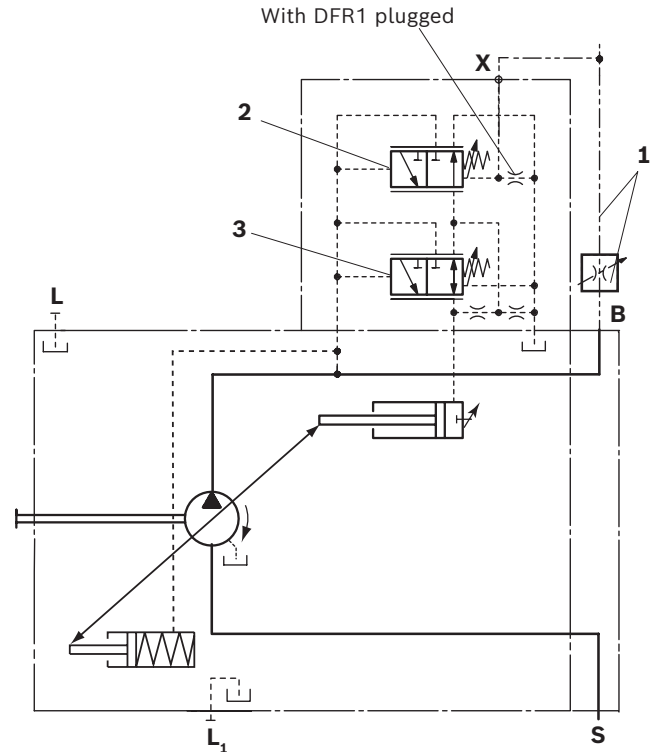

- 1 The metering orifice (control block) and the line is not included in the scope of delivery.
- 2 Flow controller (**FR**).
- 3 Pressure controller (**DR**)

For further information see page 17

- 1) In order to prevent damage to the pump and the system, the permissible setting range must not be exceeded. The range of possible settings at the valve is higher.
- 2) Zero stroke pressure from pressure setting Δp on controller (**2**)

Differential pressure Δp :

- ▶ Standard setting: 200 psi (14 bar)
 If another setting is required, please state in the plain text.
- ▶ Setting range: 200 to 320 psi (14 bar to 22 bar)

Relieving the load on port **X** to the reservoir results in a zero stroke pressure ("standby") pressure which lies about 15 to 30 psi (1 to 2 bar) higher than the defined differential pressure Δp , however, system influences are not taken into account.

Controller data

DR pressure controller data see page 14
 Maximum flow deviation measured at drive speed
 n = 1500 rpm.

NG		18	28	45	71	88	100
Flow deviation	$\Delta q_{V\ max}$						
	[gpm (l/min)]	0.20 (0.9)	0.30 (1.0)	0.50 (1.8)	0.70 (2.8)	0.90 (3.4)	1.10 (4.0)
Hysteresis and repeatability	Δp [psi (bar)]	maximum 60 (4)					
Pilot fluid consumption	[gpm (l/min)]	maximum approx. 0.8 to 1.2 (3 to 4.5) (DFR) maximum approx. 0.8 (3) (DFR1)					

DFLR – Pressure, flow and power controller

Pressure controller equipped like DR, see page 14.
Equipment of the flow controller like DFR1, see page 16.
In order to achieve a constant drive torque with varying working pressures, the swivel angle and with it the output flow from the axial piston pump is varied so that the product of flow and pressure remains constant.
Flow control is possible below the power control curve.

▼ Characteristic curve and torque characteristic

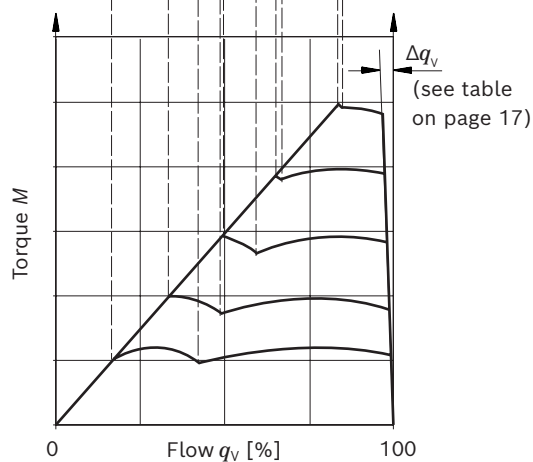
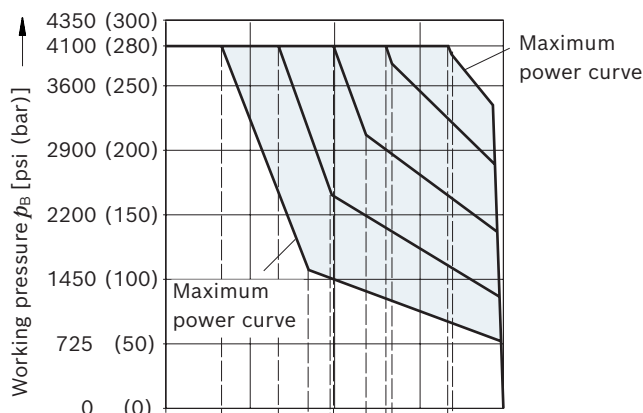

Please contact us regarding beginning of control at < 725 psi (50 bar)

When ordering please state the power characteristics to be set at the factory in plain text, e.g. 27 HP (20 kW) at 1500 rpm.

▼ Circuit diagram DFLR

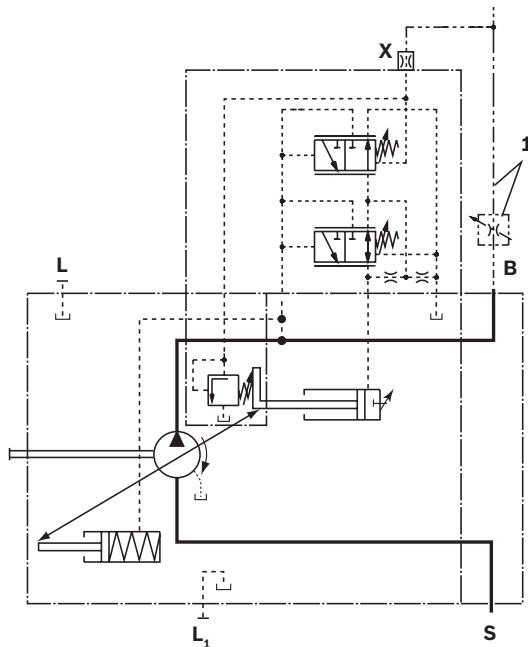

1 The metering orifice (control block) and the line is not included in the scope of delivery.

Controller data

For technical data of pressure controller DR see page 14.

For technical data of flow controller FR see page 17.

Pilot fluid consumption approx. 1.5 gpm (5.5 l/min) maximum.

ED – Electro-hydraulic pressure control

The ED valve is set to a certain pressure by a specified variable solenoid current.

When changing the consumer (load pressure), this causes an increase or decrease in the pump swivel angle (flow) in order to maintain the electrically set pressure level.

The pump thus only delivers as much hydraulic fluid as the actuators can take. The desired pressure level can be set steplessly by varying the solenoid current.

As the solenoid current signal drops towards zero, the pressure will be limited to p_{max} by an adjustable hydraulic pressure cut-off (secure fail safe function in case of power failure, e.g. for fan speed control). The swivel time characteristic of the ED control was optimized for the use as a fan drive system.

When ordering, specify the type of application in plain text.

▼ Current/pressure characteristic curve ED (negative characteristic curve)

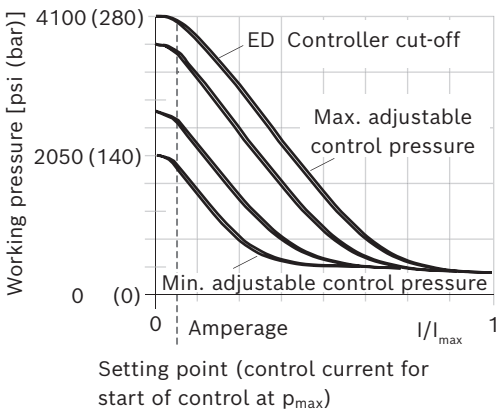

- ▶ Hysteresis static current-pressure characteristic curve < 45 psi (3 bar).

▼ Flow-pressure characteristic curve

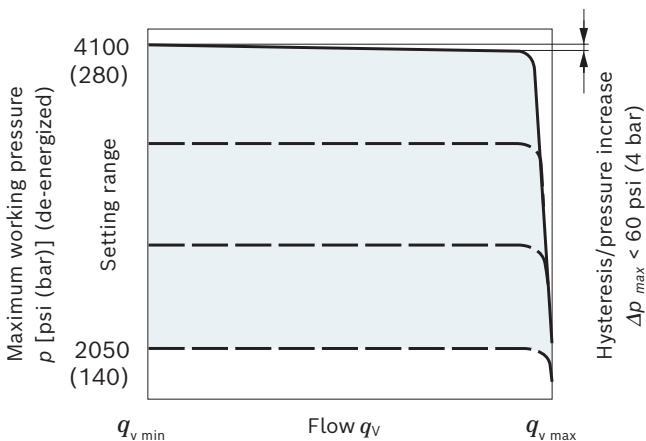

Characteristic curves valid at $n_1 = 1500$ rpm and $\vartheta_{fluid} = 122$ °F (50 °C).

- ▶ Pilot fluid consumption: 0.8 to 1.2 gpm (3 to 4.5 l/min).
- ▶ For standby standard setting, see the following diagram; other values on request.

▼ Influence of the pressure setting on standby (maximally energized)

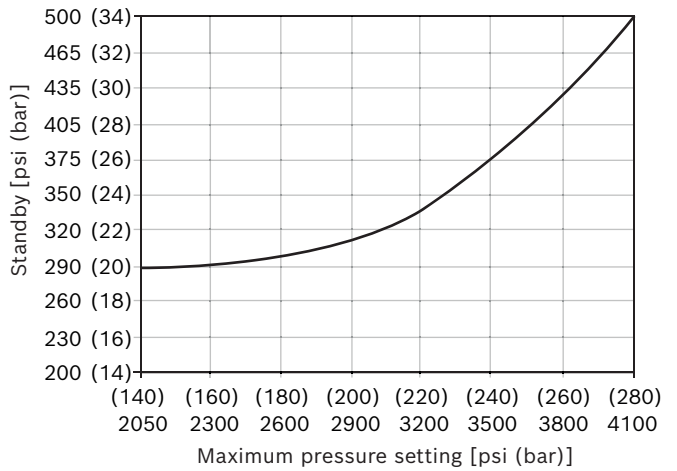

▼ Circuit diagram ED72

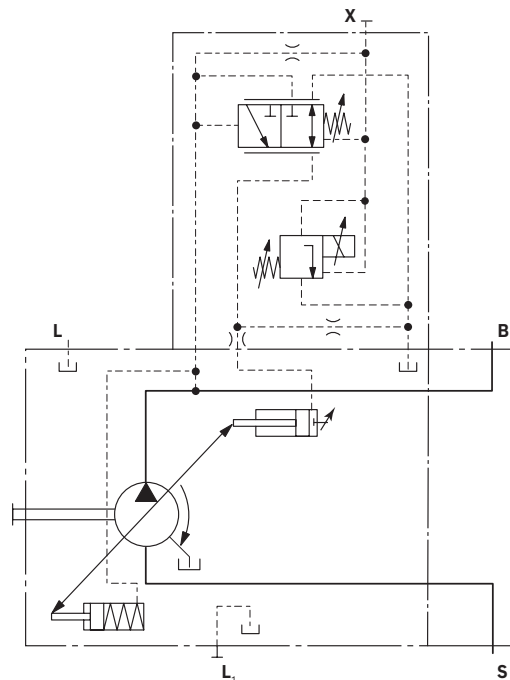

Technical data, solenoids	ED72
Voltage	24 V ($\pm 20\%$)
Control current	
Start of control at p_{\max}	50 mA
Start of control at p_{\min}	600 mA
Current limit	0.77 A
Nominal resistance (at 68 °F (20 °C))	22.7 Ω
Dither frequency	100 Hz
Recommended amplitude peak to peak	120 mA
Duty cycle	100%
Type of protection and control electronics see connector version page 42	
Operating temperature range at valve	-4 °F to +239 °F (-20 °C to +115 °C)

Notice!

With **ED72**, de-energized operating condition (jump from 50 to 0 mA) results in a pressure increase of the maximum pressure of 60 to 75 psi (4 to 5 bar).

ER – Electro-hydraulic pressure control

The ER valve is set to a certain pressure by a specified variable solenoid current.

When changing the consumer (load pressure), this causes an increase or decrease in the pump swivel angle (flow) in order to maintain the electrically set pressure level.

The pump thus only delivers as much hydraulic fluid as the consumers can take. The desired pressure level can be set steplessly by varying the solenoid current.

If the solenoid current drops towards zero, the pressure will be limited to p_{\min} (standby) by an adjustable hydraulic pressure cut-off.

Observe project planning note.

▼ Current-pressure characteristic curve (positive characteristic curve)

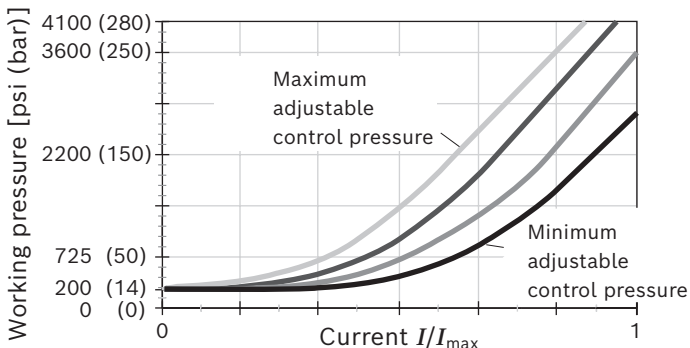

- ▶ Hysteresis static < 45 psi (3 bar).

▼ Flow-pressure characteristic curve

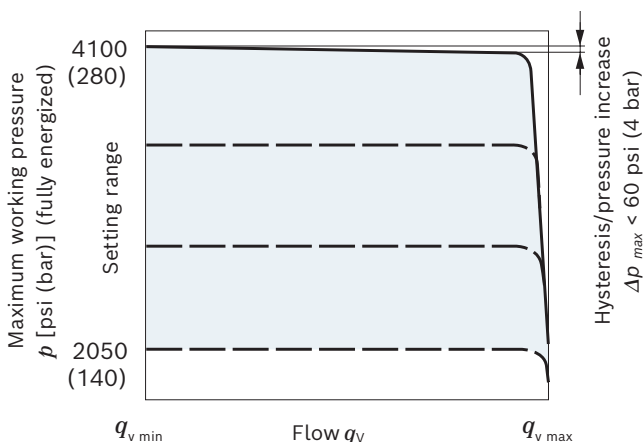

- ▶ Characteristic curves valid at $n_1 = 1500$ rpm and $\vartheta_{\text{fluid}} = 122$ °F (50 °C).
- ▶ Pilot fluid consumption: 0.8 to 1.2 gpm (3 to 4.5 l/min).
- ▶ Standby standard setting 200 psi (14 bar). Other values on request.
- ▶ Influence of pressure setting on stand by ± 30 psi (± 2 bar)

▼ Circuit diagram ER72

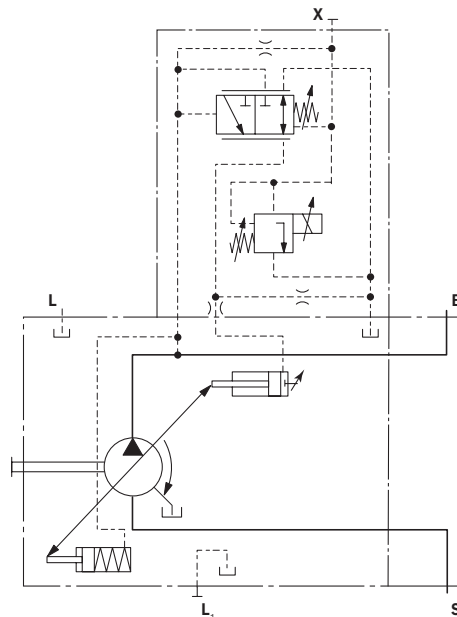

Technical data, solenoids	ER72
Voltage	24 V ($\pm 20\%$)
Control current	
Start of control at p_{\min}	50 mA
End of control at p_{\max}	600 mA
Current limit	0.77 A
Nominal resistance (at 68 °F (20 °C))	22.7 Ω
Dither frequency	100 Hz
Recommended amplitude peak to peak	120 mA
Duty cycle	100%
Type of protection and control electronics	see connector version page 42
Operating temperature range at valve	-4°F to +239°F (-20 °C to +115 °C)

Project planning note!

Over-current ($I > 600$ mA at 24 V) to the ER solenoid can result in pressure increases leading to pump or system damage. Therefore:

- ▶ Use I_{\max} current limiter solenoids.
- ▶ An intermediate plate pressure controller can be used to protect the pump in the event of overflow.

An accessory kit with intermediate plate pressure controller can be ordered from Bosch Rexroth under part number R902490825.

Dimensions, size 18

DFR/DFR1 – Pressure flow controller, hydraulic, clockwise rotation

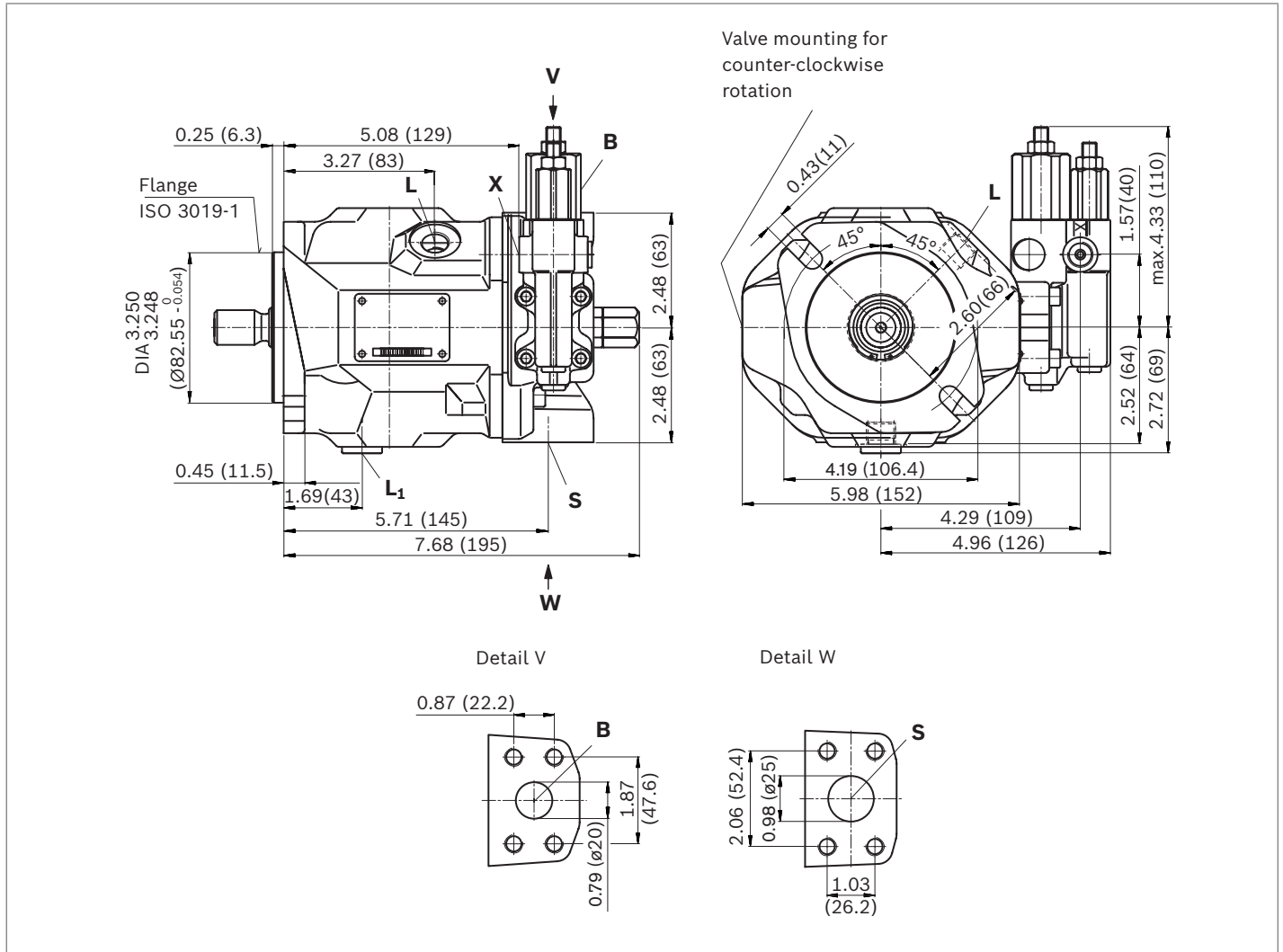

▼ **Splined shaft 3/4 in (19-4, ISO 3019-1)**

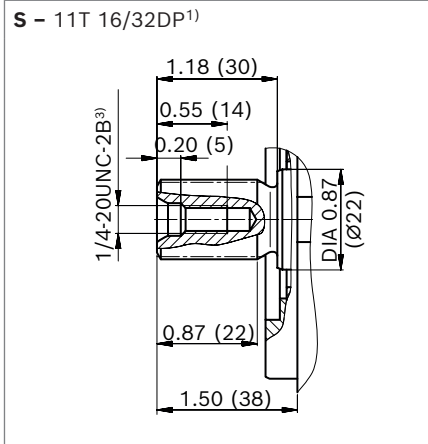

▼ **Splined shaft 3/4 in (similar to ISO 3019-1)**

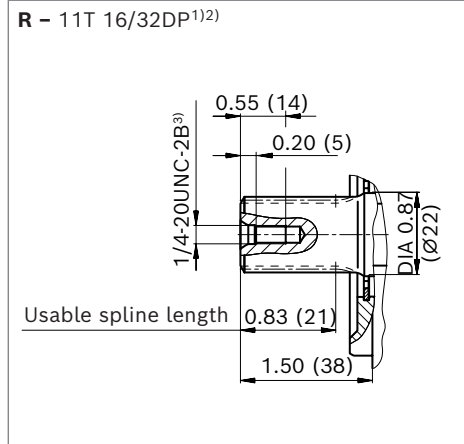

▼ **Splined shaft 5/8 in (16-4, ISO 3019-1)**

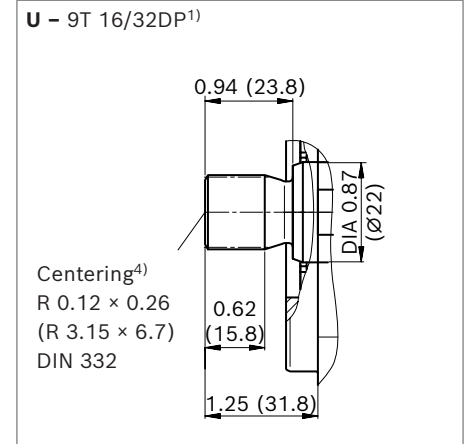

▼ **Parallel keyed shaft, ISO 3019-1**

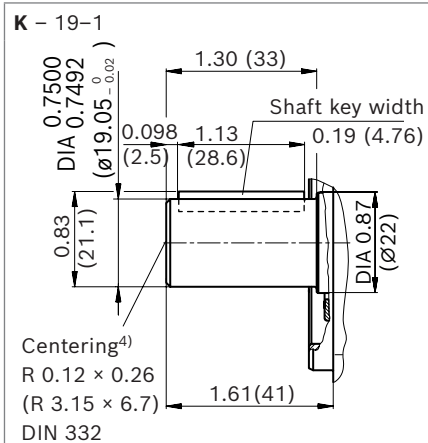

Ports		Standard	Size	p_{max} [psi (bar)] ⁵⁾	State ⁸⁾
B	Working port (standard pressure series)	ISO 6162-1	3/4 in	5100 (350)	O
	Fastening thread	ASME B1.1	3/8-16 UNC-2B; 0.79 (20) deep		
S	Suction port (standard pressure series)	ISO 6162-1	1 in	145 (10)	O
	Fastening thread	ASME B1.1	3/8-16 UNC-2B; 0.79 (20) deep		
L	Drain port	ISO 11926 ⁶⁾	9/16-18 UNF-2B; 0.51 (13) deep	30 (2)	O ⁷⁾
L₁	Drain port	ISO 11926 ⁶⁾	9/16-18 UNF-2B; 0.51 (13) deep	30 (2)	X ⁷⁾
X	Pilot pressure port	ISO 11926	7/16-20 UNF-2B; 0.45 (11.5) deep	5100 (350)	O
X	Pilot pressure port with DG-control	DIN 3852-2	G1/4 in; 0.47 (12) deep	5100 (350)	O

1) Involute spline according to ANSI B92.1a, 30° pressure angle, flat root, side fit, tolerance class 5
 2) Splines according to ANSI B92.1a, spline runout is a deviation from standard ISO 3019-1.
 3) Thread according to ASME B1.1
 4) Coupling axially secured, e.g. with a clamp coupling or radially mounted clamping screw

5) Depending on the application, momentary pressure peaks can occur. Keep this in mind when selecting measuring devices and fittings.
 6) The countersink may be deeper than specified in the standard.
 7) Depending on the installation position, **L** or **L₁** must be connected (also see installation instructions on page 43).
 8) O = Must be connected (plugged on delivery)
 X = Plugged (in normal operation)

▼ **DG - Two-point control, direct operated**

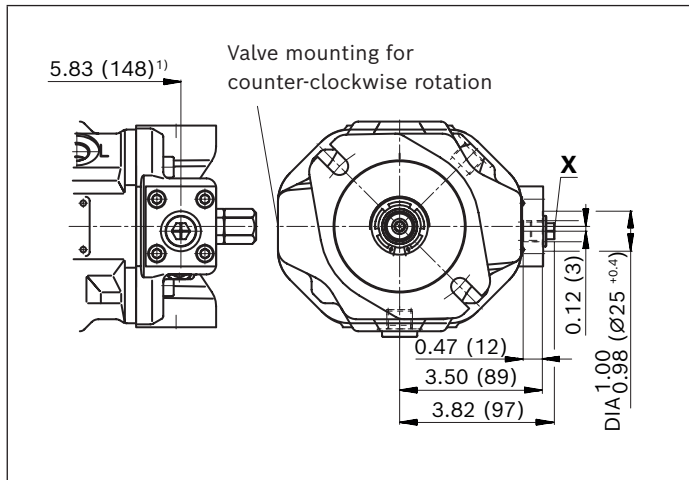

▼ **DR - Pressure controller**

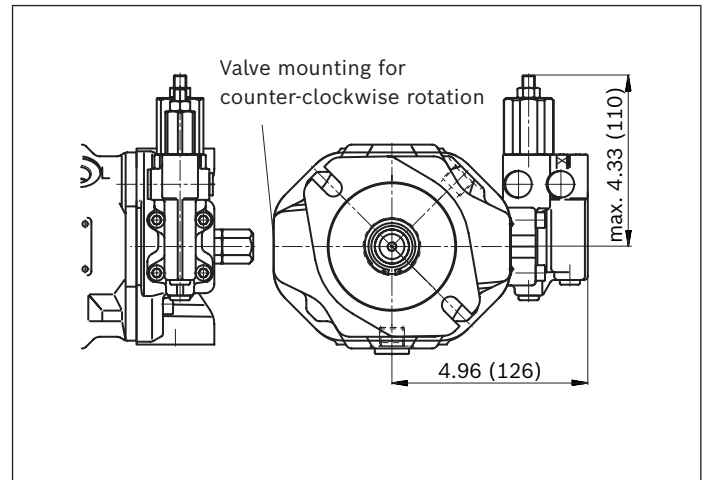

▼ **DRG - Pressure controller, remotely controlled**

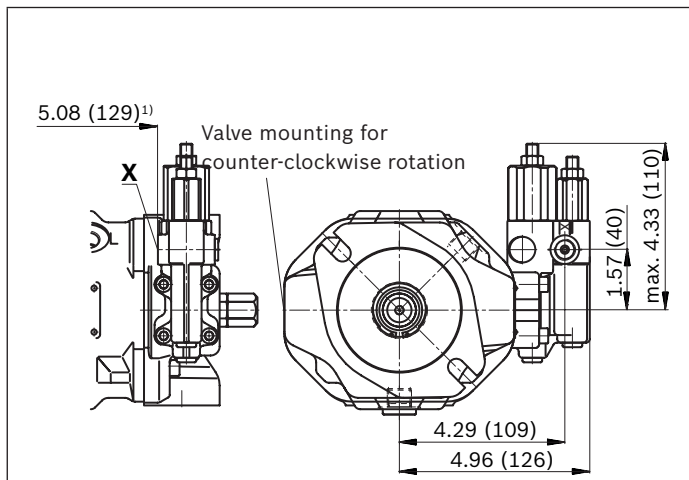

▼ **ED7., ER7. - Electro-hydraulic pressure control**

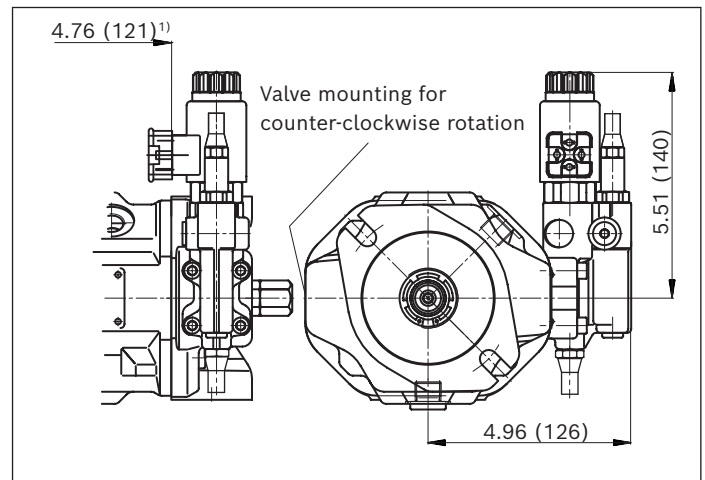

1) To flange surface

▼ **Splined shaft 7/8 in (22-4, ISO 3019-1)**

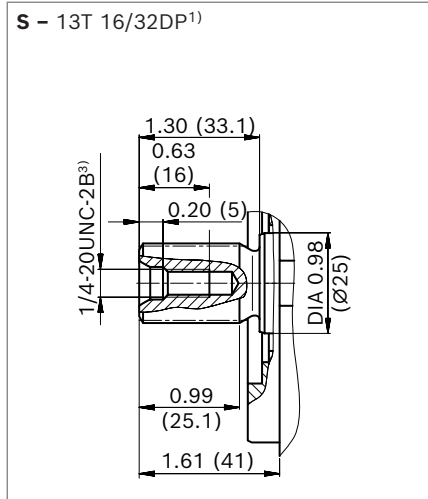

▼ **Splined shaft 7/8 in (similar to ISO 3019-1)**

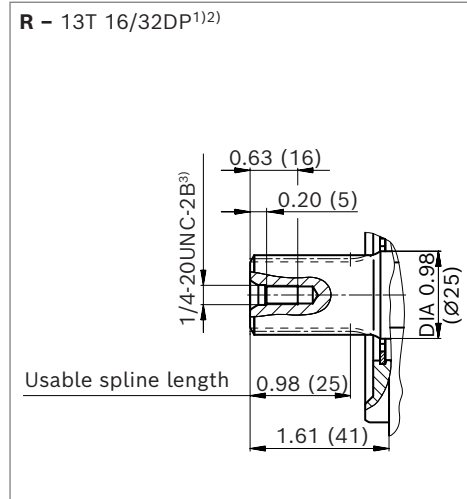

▼ **Parallel keyed shaft, ISO 3019-1**

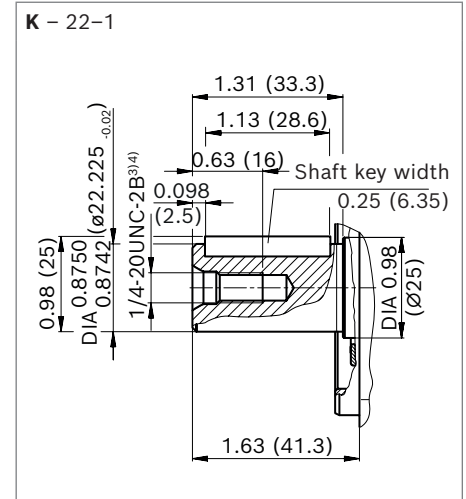

Ports	Standard	Size	p_{max} [psi (bar)] ⁴⁾	State ⁷⁾
B	Working port (standard pressure series) Fastening thread	ISO 6162-1 ASME B1.1	3/4 in 3/8-16 UNC-2B; 0.79 (20) deep	5100 (350) O
S	Suction port (standard pressure series) Fastening thread	ISO 6162-1 ASME B1.1	1 1/4 in 7/16-14 UNC-2B; 0.94 (24) deep	145 (10) O
L	Drain port	ISO 11926 ⁵⁾	3/4-16 UNF-2B; 0.59 (15) deep	30 (2) O ⁶⁾
L₁	Drain port	ISO 11926 ⁵⁾	3/4-16 UNF-2B; 0.59 (15) deep	30 (2) X ⁶⁾
X	Pilot pressure port	ISO 11926	7/16-20 UNF-2B; 0.45 (11.5) deep	5100 (350) O
X	Pilot pressure port with DG-control	DIN 3852-2	G1/4 in; 0.47 (12) deep	5100 (350) O

1) Involute spline according to ANSI B92.1a, 30° pressure angle, flat root, side fit, tolerance class 5
 2) Splines according to ANSI B92.1a, spline runout is a deviation from standard ISO 3019-1.
 3) Thread according to ASME B1.1
 4) Depending on the application, momentary pressure peaks can occur. Keep this in mind when selecting measuring devices and fittings.

5) The countersink may be deeper than specified in the standard.
 6) Depending on the installation position, **L** or **L₁** must be connected (also see installation instructions on page 43).
 7) O = Must be connected (plugged on delivery)
 X = Plugged (in normal operation)

▼ **DG - Two-point control, direct operated**

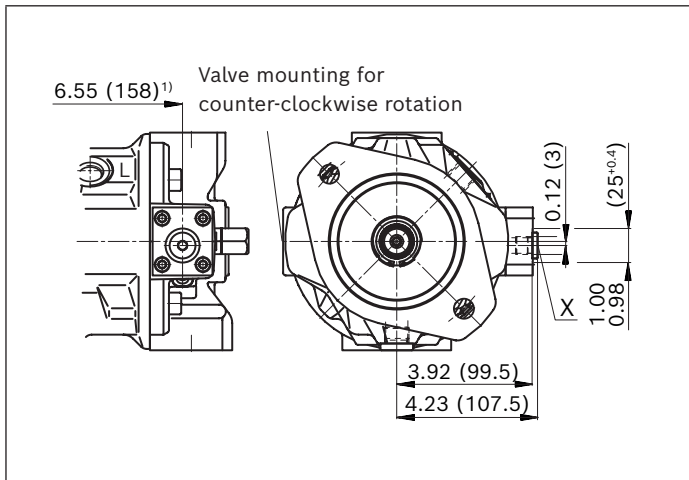

▼ **DFLR - Pressure, flow and power controller**

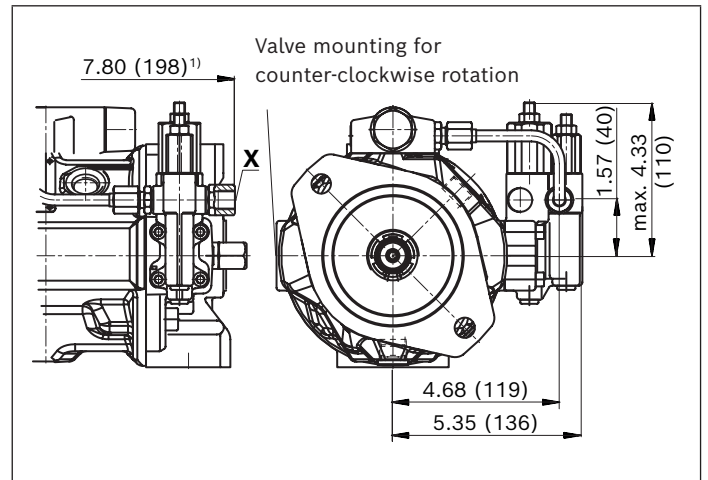

▼ **DR - Pressure controller**

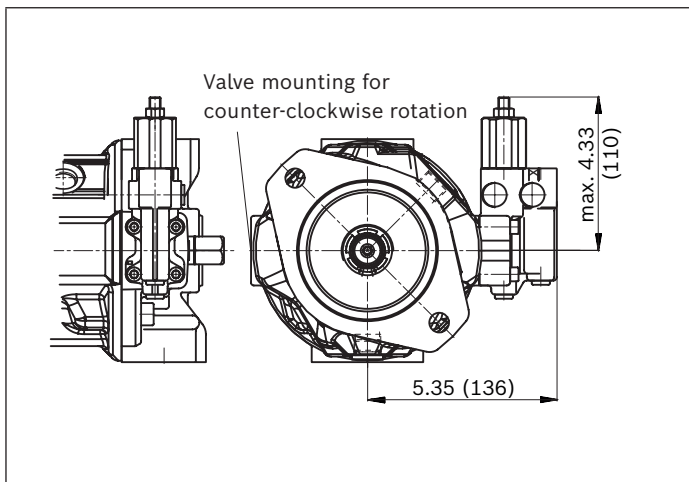

▼ **DRG - Pressure controller, remotely controlled**

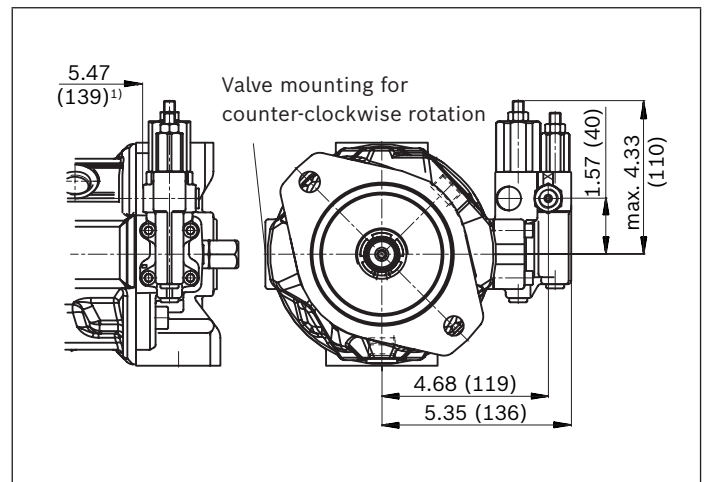

▼ **ED7., ER7. - Electro-hydraulic pressure control**

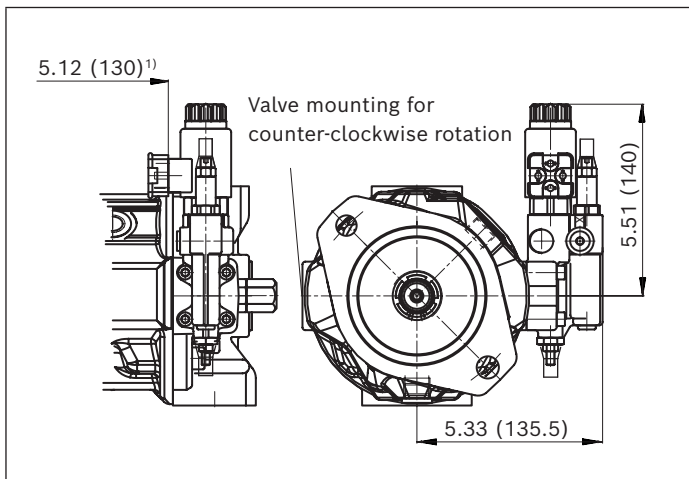

1) To flange surface

Dimensions, size 45

DFR/DFR1 – Pressure flow controller, hydraulic, clockwise rotation

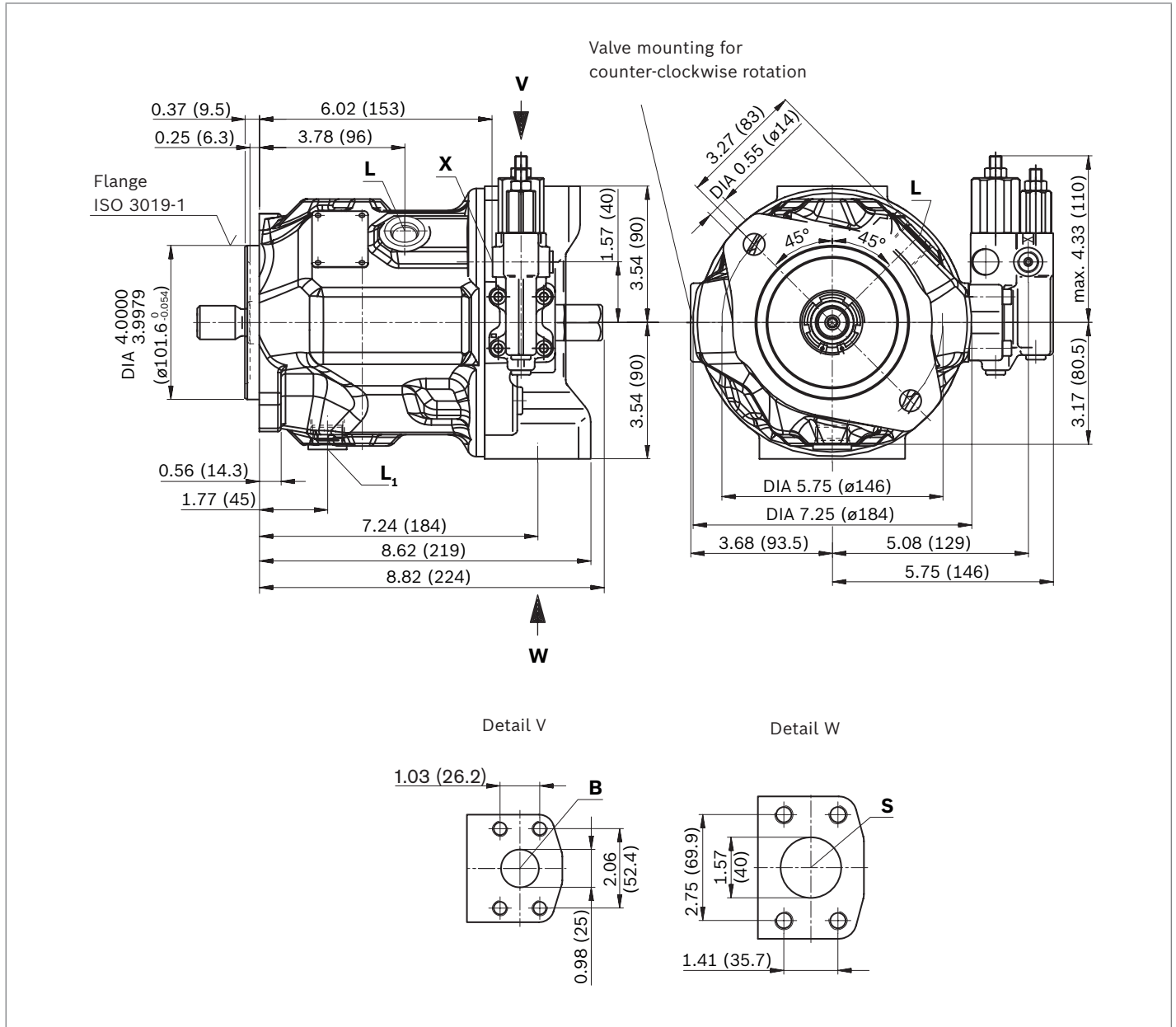

▼ **Splined shaft 1 in (25-4, ISO 3019-1)**

S – 15T 16/32DP¹⁾

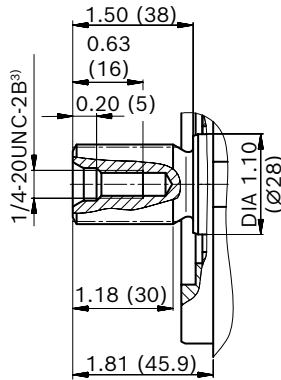

▼ **Splined shaft 1 in (similar to ISO 3019-1)**

R – 15T 16/32DP¹⁾²⁾

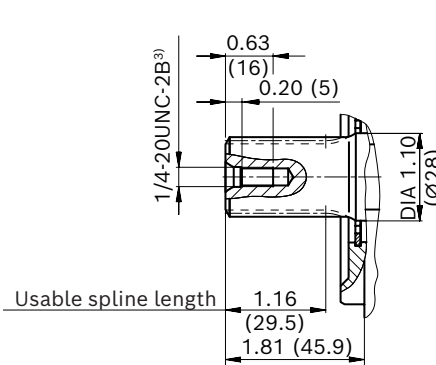

▼ **Parallel keyed shaft, ISO 3019-1**

K – 25-1

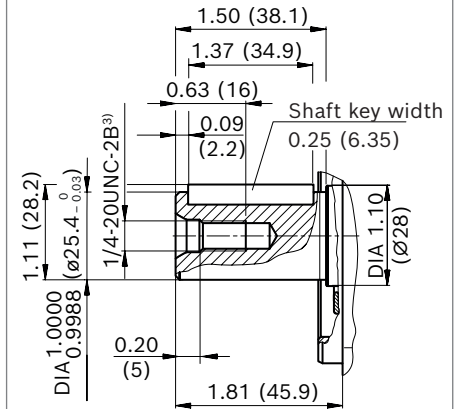

Ports		Standard	Size	p_{max} [psi (bar)] ⁴⁾	State ⁷⁾
B	Working port (standard pressure series)	ISO 6162-1	1 in	5100 (350)	O
	Fastening thread	ASME B1.1	3/8-16 UNC-2B; 0.67 (17) deep		
S	Suction port (standard pressure series)	ISO 6162-1	1 1/2 in	145 (10)	O
	Fastening thread	ASME B1.1	1/2-13 UNC-2B; 0.79 (20) deep		
L	Drain port	ISO 11926 ⁵⁾	7/8-14 UNF-2B; 0.67 (17) tief	30 (2)	O ⁶⁾
L₁	Drain port	ISO 11926 ⁵⁾	7/8-14 UNF-2B; 0.67 (17) deep	30 (2)	X ⁶⁾
X	Pilot pressure port	ISO 11926	7/16-20 UNF-2B; 0.45 (11.5) deep	5100 (350)	O
X	Pilot pressure port with DG-control	DIN 3852-2	G1/4 in; 0.47 (12) deep	5100 (350)	O

1) Involute spline according to ANSI B92.1a, 30° pressure angle, flat root, side fit, tolerance class 5
 2) Splines according to ANSI B92.1a, spline runout is a deviation from standard ISO 3019-1.
 3) Thread according to ASME B1.1
 4) Depending on the application, momentary pressure peaks can occur.
 Keep this in mind when selecting measuring devices and fittings.

5) The countersink may be deeper than specified in the standard.
 6) Depending on the installation position, **L** or **L₁** must be connected (also see installation instructions on page 43).
 7) O = Must be connected (plugged on delivery)
 X = Plugged (in normal operation)

▼ **DG - Two-point control, direct operated**

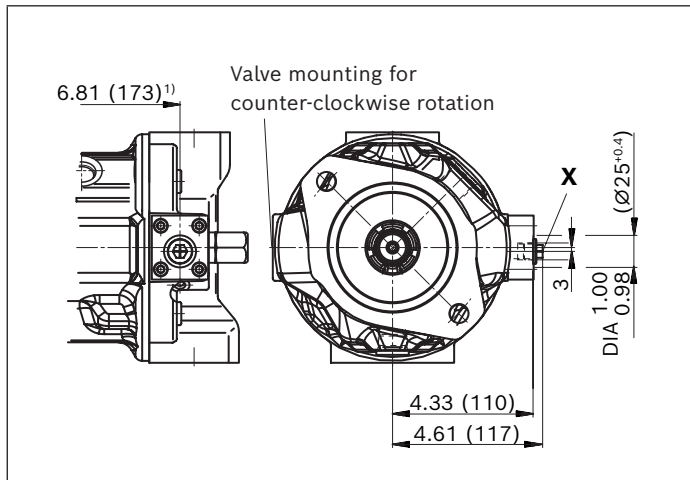

▼ **DFLR - Pressure, flow and power controller**

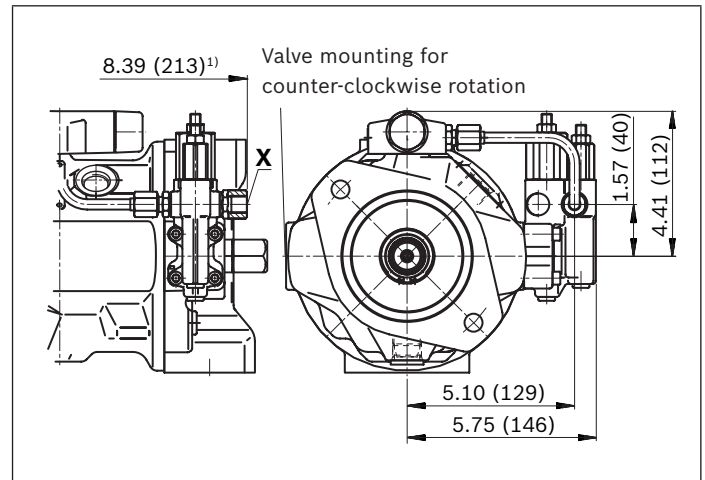

▼ **DR - Pressure controller**

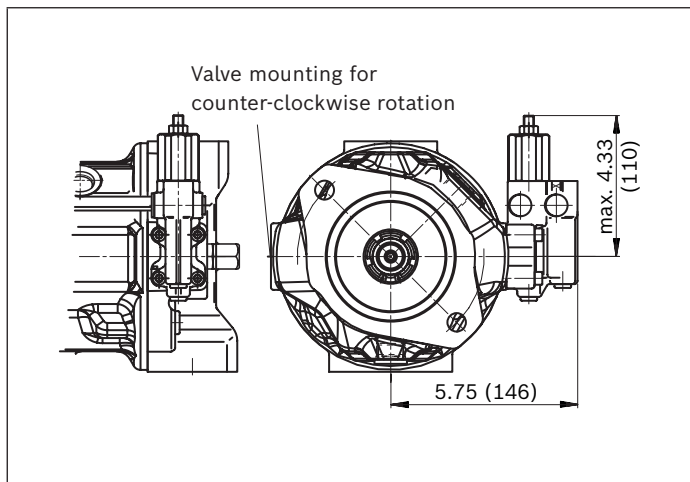

▼ **DRG - Pressure controller, remotely controlled**

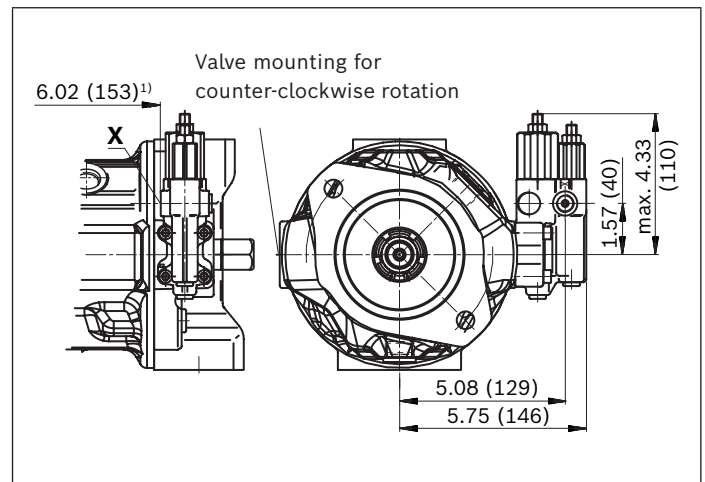

▼ **ED7., ER7. - Electro-hydraulic pressure control**

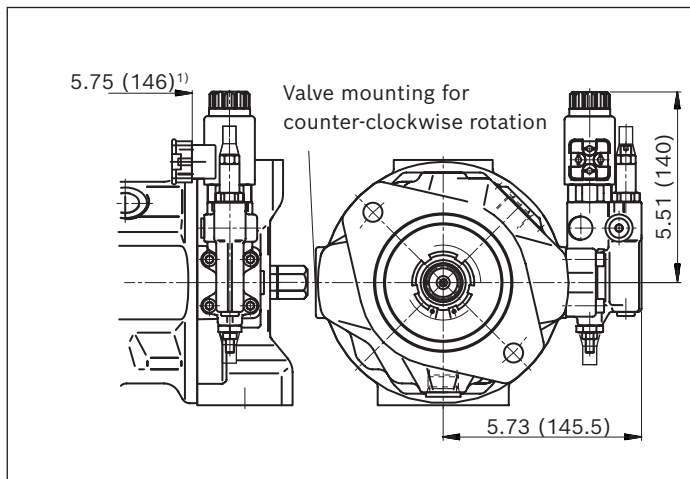

1) To flange surface

Dimensions, sizes 71 and 88

DFR/DFR1 – Pressure flow controller, hydraulic, clockwise rotation

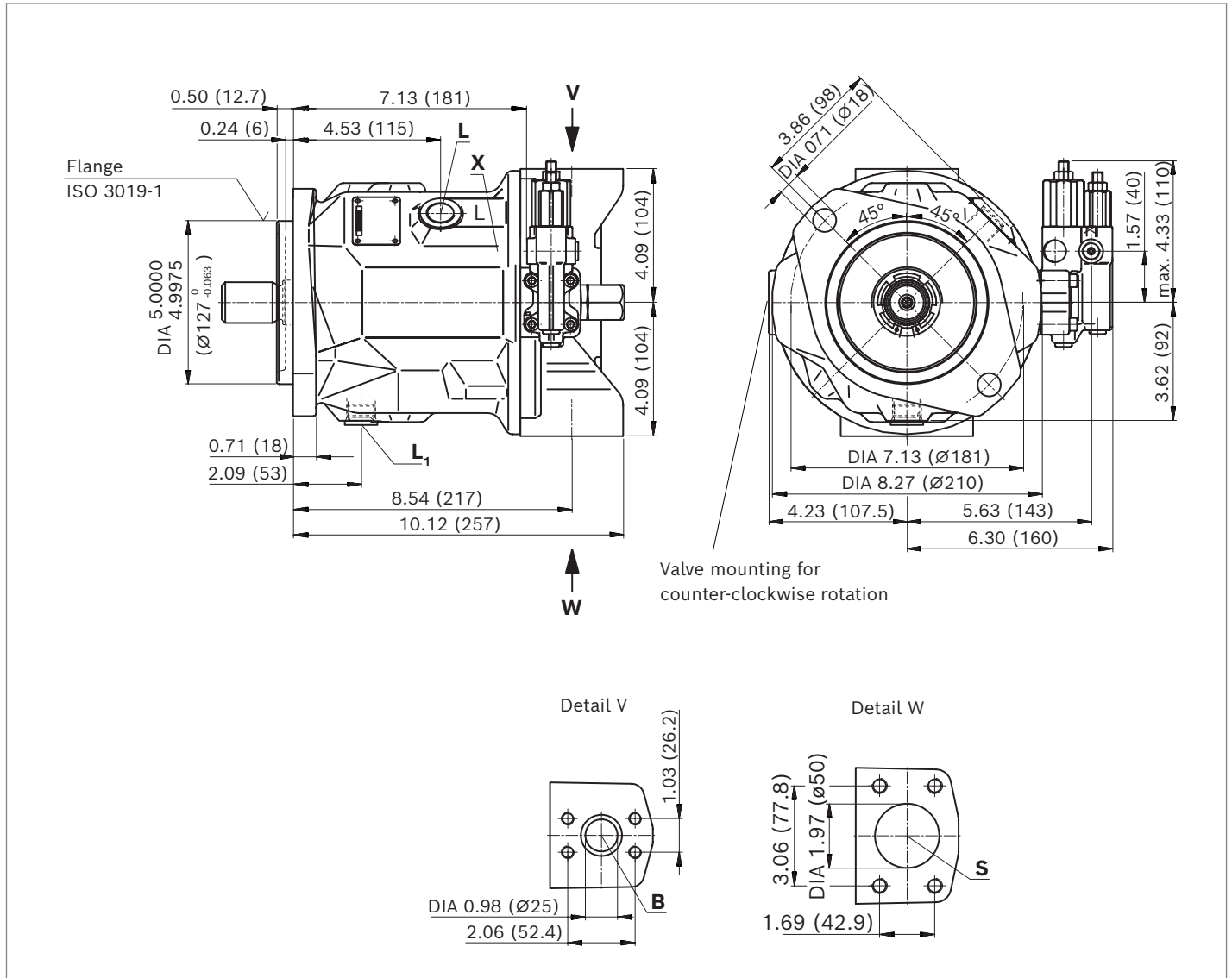

▼ **Splined shaft 1 1/4 in (32-4, ISO 3019-1)**

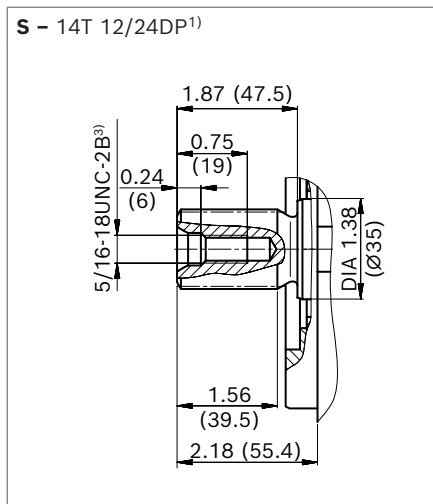

▼ **Splined shaft 1 1/4 in (similar to ISO 3019-1)**

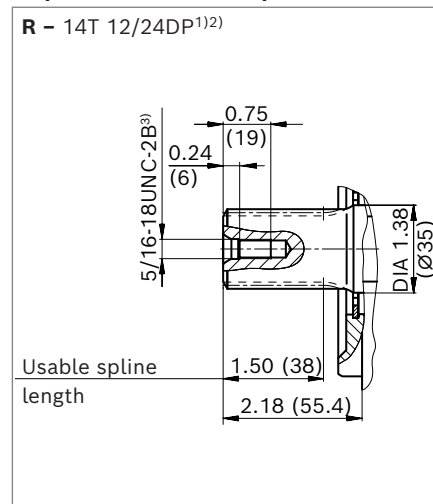

▼ **Parallel keyed shaft, ISO 3019-1**

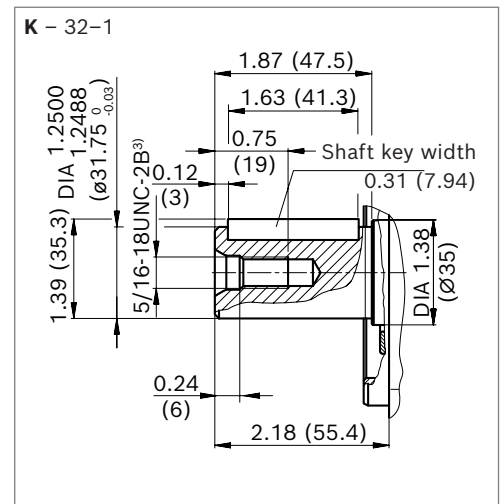

Ports		Standard	Size	p_{max} [psi (bar)] ⁴⁾	State ⁷⁾
B	Working port (standard pressure series) Fastening thread	ISO 6162-1 ASME B1.1	1 in 3/8-16 UNC-2B; 0.71 (18) deep	5100 (350)	O
S	Suction port (standard pressure series) Fastening thread	ISO 6162-1 ASME B1.1	2 in 1/2-13UNC-2B; 0.87 (22) deep	145 (10)	O
L	Drain port	ISO 11926 ⁵⁾	7/8-14 UNF-2B; 0.67 (17) deep	30 (2)	O ⁶⁾
L₁	Drain port	ISO 11926 ⁵⁾	7/8-14 UNF-2B; 0.67 (17)) deep	30 (2)	X ⁶⁾
X	Pilot pressure port	ISO 11926	7/16-20 UNF-2B; 0.45 (11.5) deep	5100 (350)	O
X	Pilot pressure port with DG-control	DIN 3852-2	G1/4 in; 0.47 (12) deep	5100 (350)	O

1) Involute spline according to ANSI B92.1a, 30° pressure angle, flat root, side fit, tolerance class 5
2) Splines according to ANSI B92.1a, spline runout is a deviation from standard ISO 3019-1.
3) Thread according to ASME B1.1
4) Depending on the application, momentary pressure peaks can occur. Keep this in mind when selecting measuring devices and fittings.

5) The countersink may be deeper than specified in the standard.
6) Depending on the installation position, **L** or **L₁** must be connected (also see installation instructions on page 43).
7) O = Must be connected (plugged on delivery)
X = Plugged (in normal operation)

▼ **DG - Two-point control, direct operated**

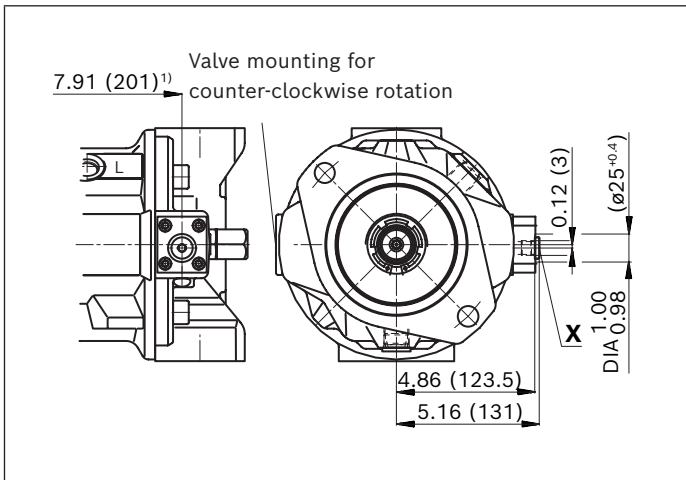

▼ **DFLR - Pressure, flow and power controller**

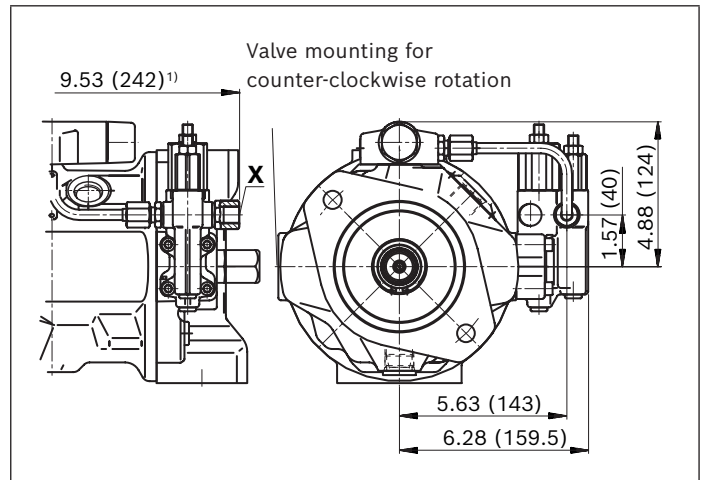

▼ **DR - Pressure controller**

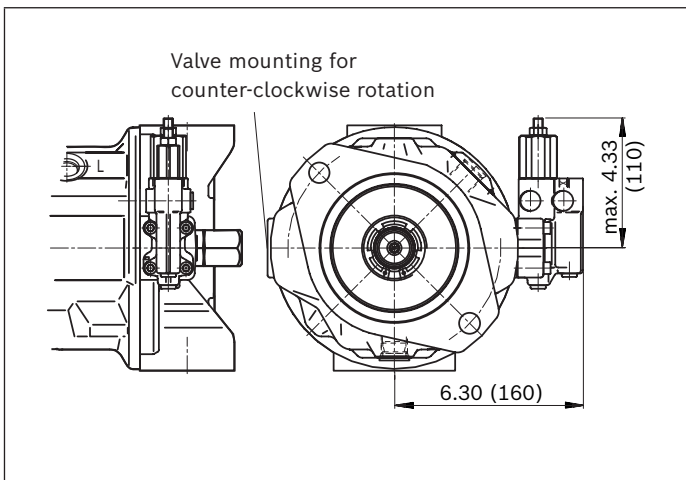

▼ **DRG - Pressure controller, remotely controlled**

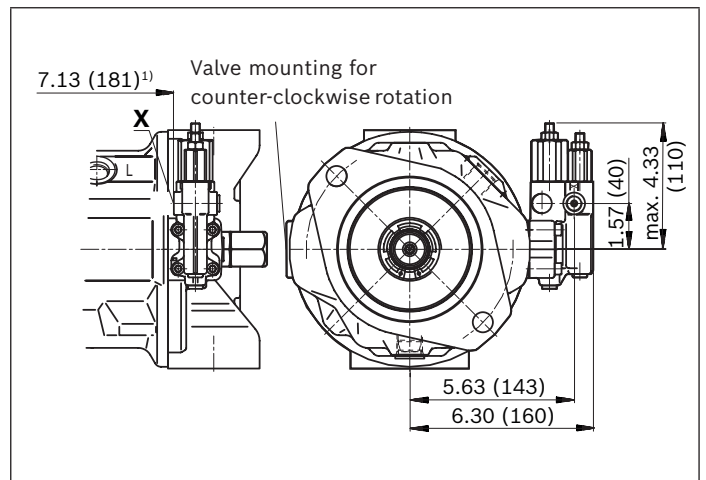

▼ **ED7., ER7. - Electro-hydraulic pressure control**

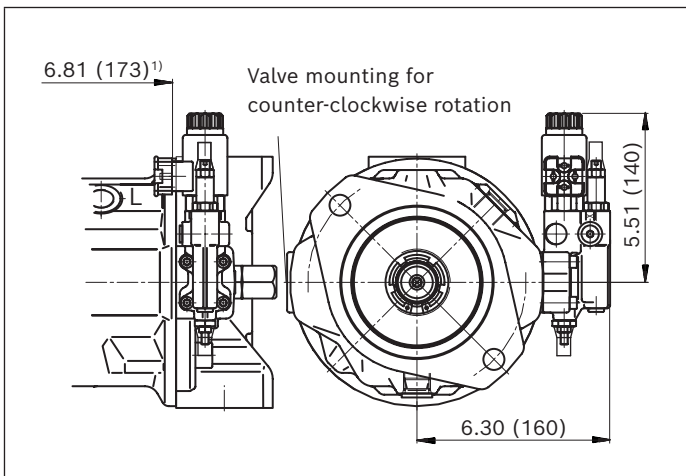

1) To flange surface

Dimensions, size 100

DFR/DFR1 – Pressure flow controller, hydraulic, clockwise rotation

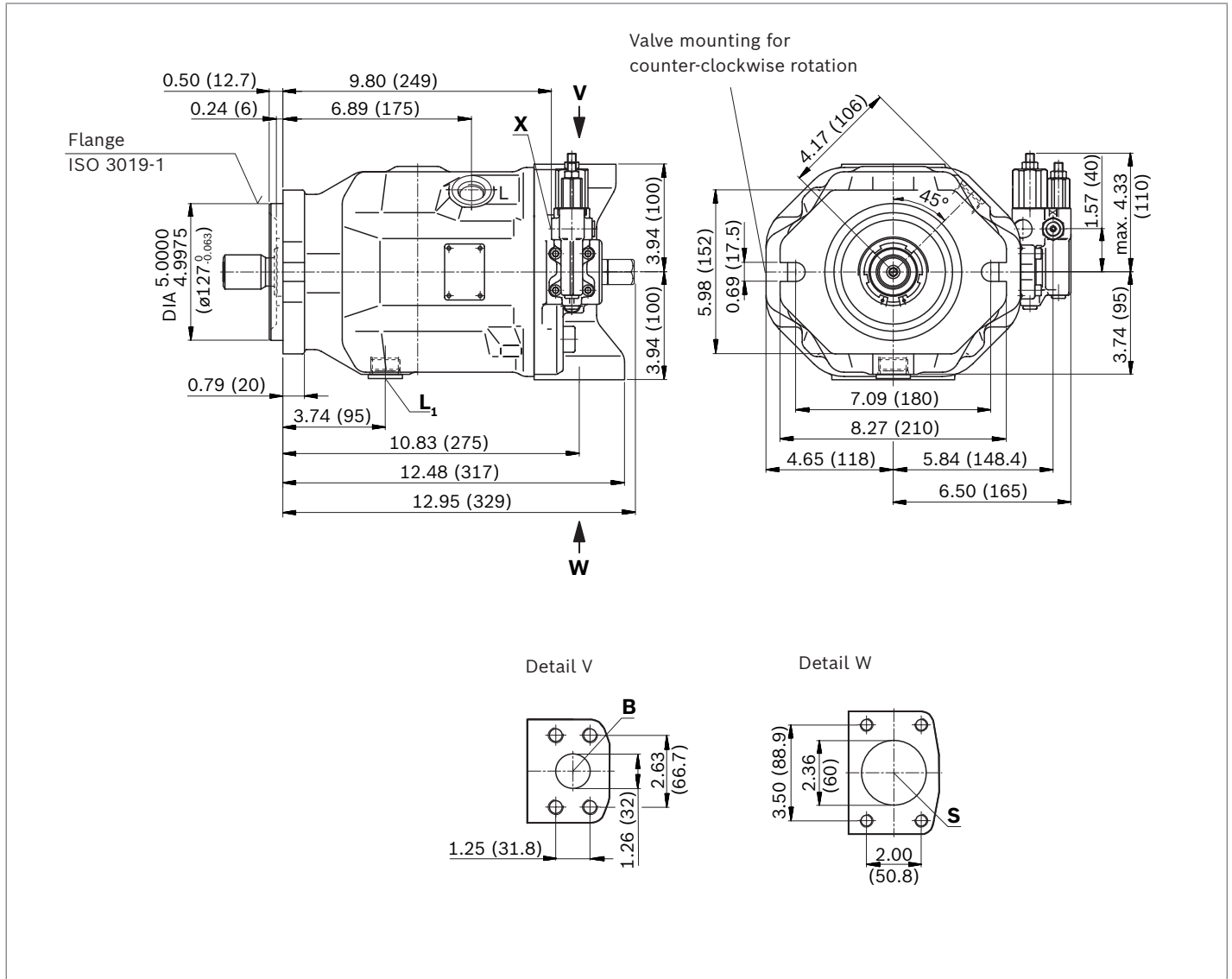

▼ **Splined shaft 1 1/2 in (38-4, ISO 3019-1)**

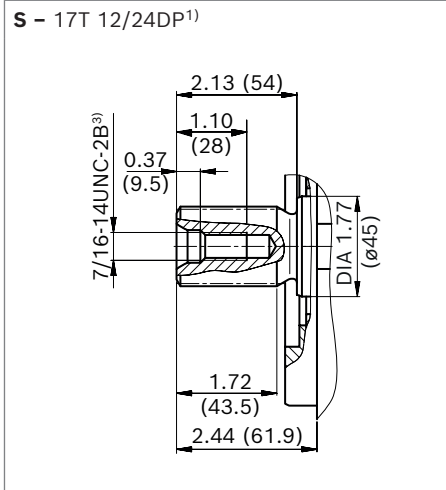

▼ **Splined shaft 1 1/4 in (32-4, ISO 3019-1)**

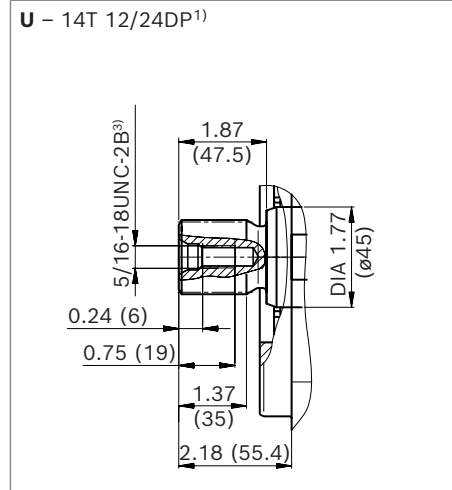

▼ **Parallel keyed shaft, ISO 3019-1**

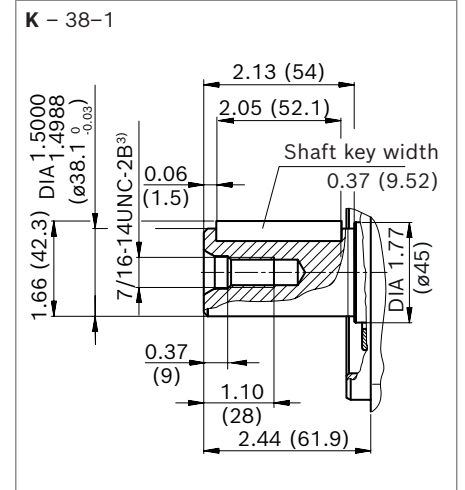

Ports		Standard	Size ⁴⁾	p_{max} [psi (bar)] ⁴⁾	State ⁷⁾
B	Working port (high-pressure series) Fastening thread	ISO 6162-2 ASME B1.1	1 1/4 in 1/2-13 UNC-2B; 0.75 (19) deep	5100 (350)	O
S	Suction port (standard pressure series) Fastening thread	ISO 6162-1 ASME B1.1	2 1/2 in 1/2-13 UNC-2B; 1.06 (27) deep	145 (10)	O
L	Drain port	ISO 11926 ⁵⁾	1 1/16-12 UNF-2B; 0.79 (20) deep	30 (2)	O ⁶⁾
L₁	Drain port	ISO 11926 ⁵⁾	1 1/16-12 UNF-2B; 0.79 (20) deep	30 (2)	X ⁶⁾
X	Pilot pressure port	ISO 11926	7/16-20 UNF-2B; 0.45 (11.5) deep	5100 (350)	O
X	Pilot pressure port with DG-control	DIN 3852-2	G1/4 in; 0.47 (12) deep	5100 (350)	O

1) Involute spline according to ANSI B92.1a, 30° pressure angle, flat root, side fit, tolerance class 5
 2) Splines according to ANSI B92.1a, spline runout is a deviation from standard ISO 3019-1.
 3) Thread according to ASME B1.1
 4) Depending on the application, momentary pressure peaks can occur. Keep this in mind when selecting measuring devices and fittings.

5) The countersink may be deeper than specified in the standard.
 6) Depending on the installation position, **L** or **L₁** must be connected (also see installation instructions on page 43).
 7) O = Must be connected (plugged on delivery)
 X = Plugged (in normal operation)

▼ **DG - Two-point control, direct operated**

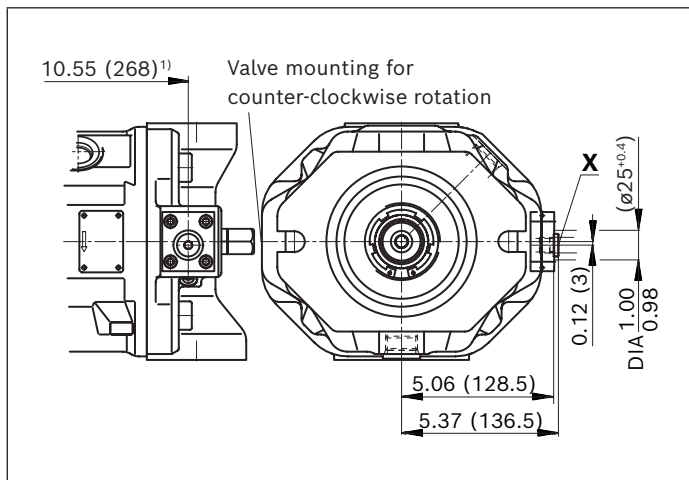

▼ **DFLR - Pressure, flow and power controller**

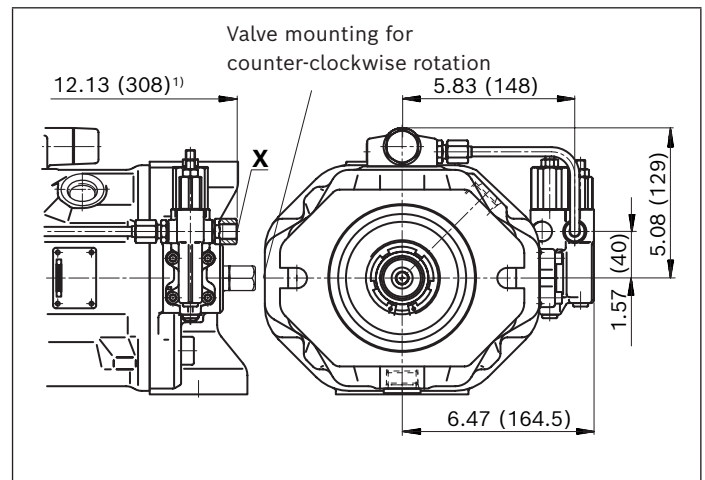

▼ **DR - Pressure controller**

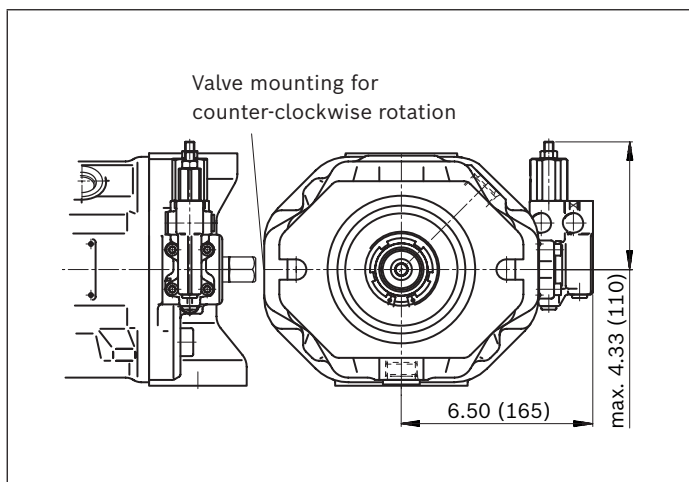

▼ **DRG - Pressure controller, remotely controlled**

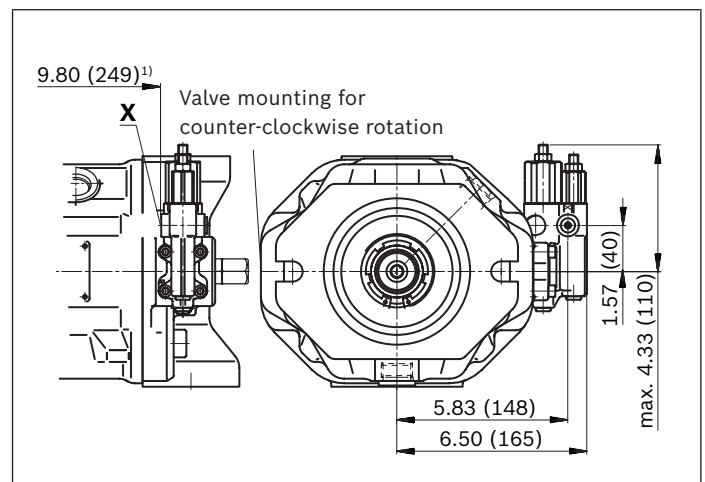

▼ **ED7., ER7. - Electro-hydraulic pressure control**

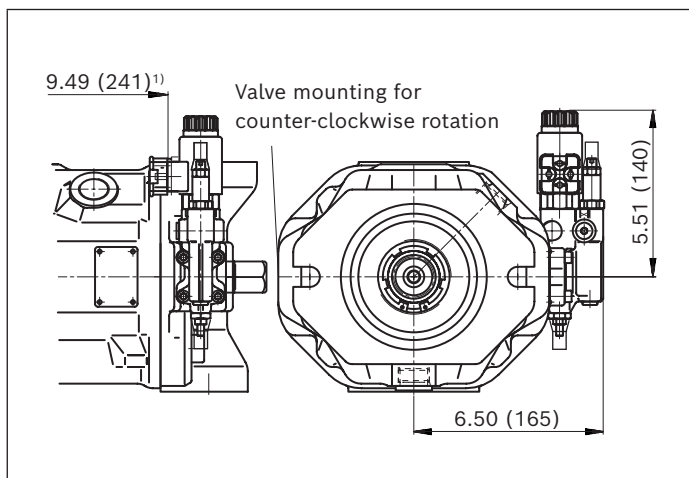

1) To flange surface

Dimensions, through drive

For flanges and shafts according to ISO 3019-1

Flange (SAE)		Hub for splined shaft ¹⁾		Availability across sizes						Code
Diameter	Mounting ⁴⁾	Diameter		18	28	45	71	88	100	
82-2 (A)	⌀, ⌀ ^p , ∞	5/8 in	9T 16/32DP	•	•	•	•	•	•	K01
		3/4 in	11T 16/32DP	•	•	•	•	•	•	K52

▼ 82-2

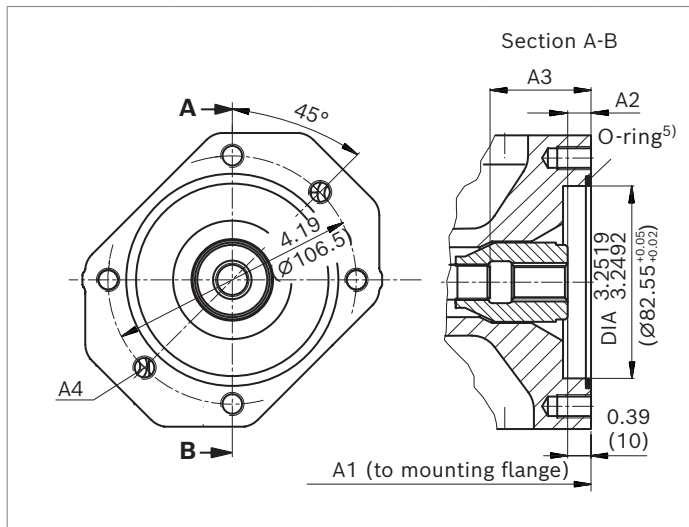

K01 (16-4 (A))	NG	A1	A2 ³⁾	A3 ³⁾	A4 ²⁾
18	7.17 (182)	0.37 (9.3)	1.67 (42.5)	M10×1.5; 0.57 (14.5) deep	
28	8.03 (204)	0.36 (9.2)	1.42 (36.2)	M10×1.5; 0.63 (16) deep	
45	9.02 (229)	0.40 (10.1)	2.07 (52.7)	M10×1.5; 0.63 (16) deep	
71	10.50 (267)	0.44 (11.2)	2.38 (60.6)	M10×1.5; 0.79 (20) deep	
88	10.50 (267)	0.44 (11.2)	2.38 (60.6)	M10×1.5; 0.79 (20) deep	
100	13.30 (338)	0.39 (10.0)	2.53 (64.3)	M10×1.5; 0.63 (16) deep	

1) According to ANSI B92.1a, 30° pressure angle, flat root, side fit, tolerance class 5
 2) Thread according to DIN 13
 3) Minimum dimensions

▼ 82-2

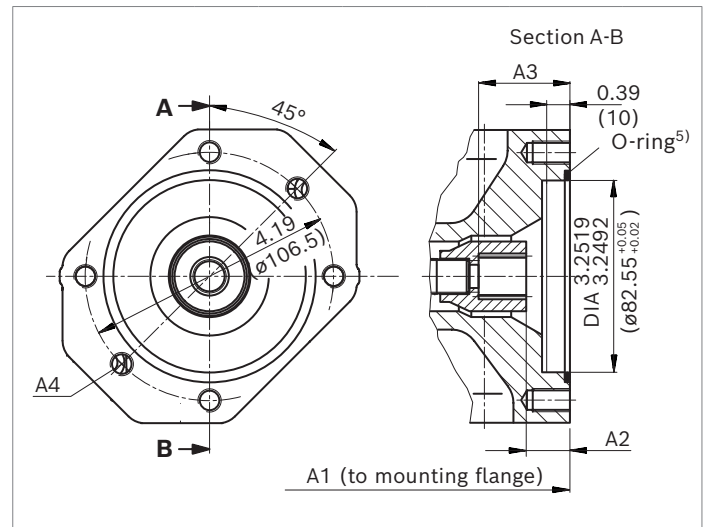

K52 (19-4 (A-B))	NG	A1	A2 ³⁾	A3 ³⁾	A4 ²⁾
18	7.17 (182)	0.71 (18.3)	1.54 (39.2)	M10×1.5; 0.57 (14.5) deep	
28	8.03 (204)	0.72 (18.4)	1.55 (39.4)	M10×1.5; 0.63 (16) deep	
45	9.02 (229)	0.72 (18.4)	1.52 (38.8)	M10×1.5; 0.63 (16) deep	
71	10.50 (267)	0.82 (20.8)	1.62 (41.2)	M10×1.5; 0.79 (20) deep	
88	10.50 (267)	0.82 (20.8)	1.62 (41.2)	M10×1.5; 0.79 (20) deep	
100	13.30 (338)	0.73 (18.6)	1.56 (39.6)	M10×1.5; 0.63 (16) deep	

4) Mounting holes pattern viewed on through drive with control at top
 5) O-ring included in the scope of delivery

For flanges and shafts according to ISO 3019-1

Flange (SAE)		Hub for splined shaft ¹⁾		Availability across sizes						Code
Diameter	Mounting ⁵⁾	Diameter		18	28	45	71	88	100	
101-2 (B)	ø, ø ^o , ∞	7/8 in	13T 16/32DP	-	●	●	●	●	●	K68
		1 in	15T 16/32DP	-	-	●	●	●	●	K04

▼ **101-2**

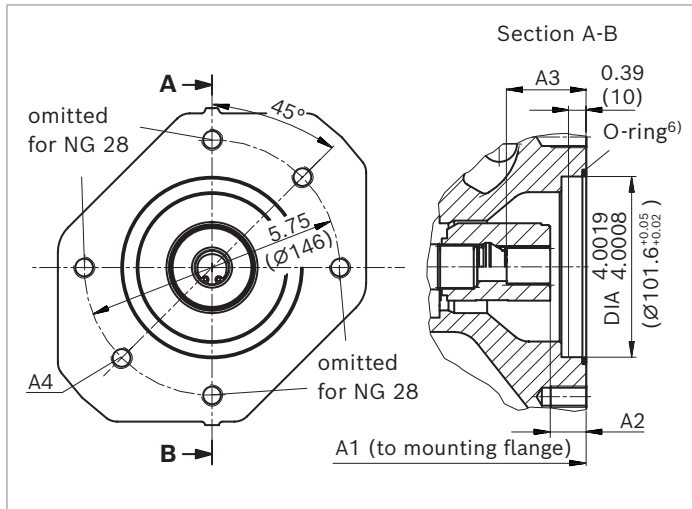

▼ **101-2**

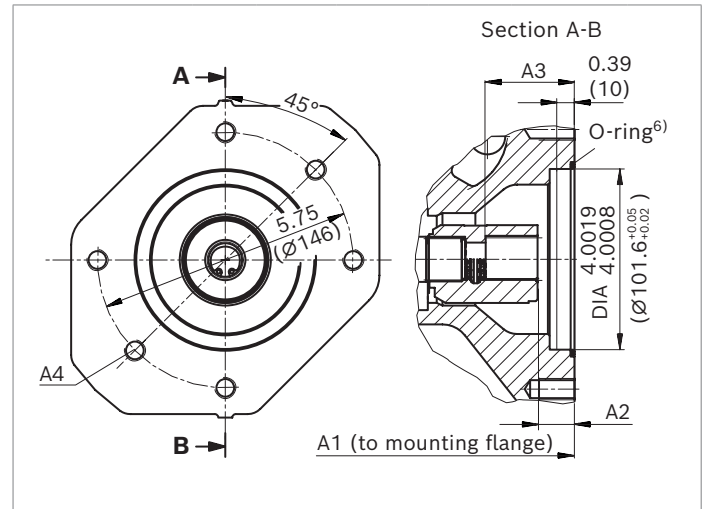

K68 (22-4 (B))	NG	A1	A2 ⁴⁾	A3 ⁴⁾	A4 ²⁾
	28	8.03 (204)	0.68 (17.4)	1.67 (42.4)	M12×1.75 ³⁾
	45	9.02 (229)	0.68 (17.4)	1.64 (41.8)	M12 × 1.75; 0.71 (18) deep
	71	10.50 (267)	0.78 (19.8)	1.74 (44.2)	M12 × 1.75; 0.79 (20) deep
	88	10.50 (267)	0.78 (19.8)	1.74 (44.2)	M12 × 1.75; 0.79 (20) deep
	100	13.30 (338)	0.69 (17.6)	1.65 (41.9)	M12 × 1.75; 0.79 (20) deep

K04 (25-4 (B-B))	NG	A1	A2 ⁴⁾	A3 ⁴⁾	A4 ²⁾
	45	9.02 (229)	0.70 (17.9)	1.87 (47.4)	M12 × 1.75; 0.71 (18) deep
	71	10.50 (267)	0.80 (20.3)	1.94 (49.2)	M12 × 1.75; 0.79 (20) deep
	88	10.50 (267)	0.80 (20.3)	1.94 (49.2)	M12 × 1.75; 0.79 (20) deep
	100	13.30 (338)	0.70 (17.8)	1.83 (46.6)	M12 × 1.75; 0.79 (20) deep

1) According to ANSI B92.1a, 30° pressure angle, flat root, side fit, tolerance class 5

2) Thread according to DIN 13

3) Continuous

4) Minimum dimensions

5) Mounting holes pattern viewed on through drive with control at top

6) O-ring included in the scope of delivery

For flanges and shafts according to ISO 3019-1

Flange (SAE)		Hub for splined shaft ¹⁾		Availability across sizes						Code
Diameter	Mounting ⁵⁾	Diameter		18	28	45	71	88	100	
127-2 (C)	♂, ∞	1 1/4 in	14T 12/24DP	-	-	-	•	•	•	K07
		1 1/2 in	17T 12/24DP	-	-	-	-	-	•	K24

▼ **127-2**

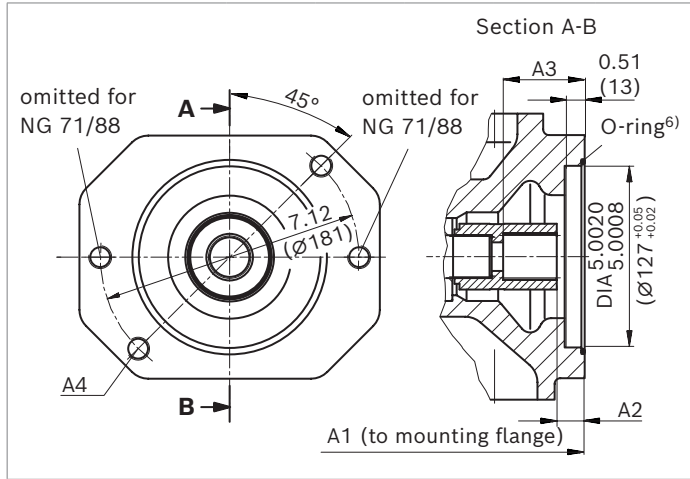

K07 (32-4 (C))	NG	A1	A2 ⁴⁾	A3 ⁴⁾	A4 ²⁾
	71	10.50 (267)	0.80 (20.3)	2.29 (58.3)	M16×2 ³⁾
	88	10.50 (267)	0.80 (20.3)	2.29 (58.3)	M16×2 ³⁾
	100	13.30 (338)	0.75 (19.1)	2.24 (57.1)	M16×2 ³⁾

▼ **127-2**

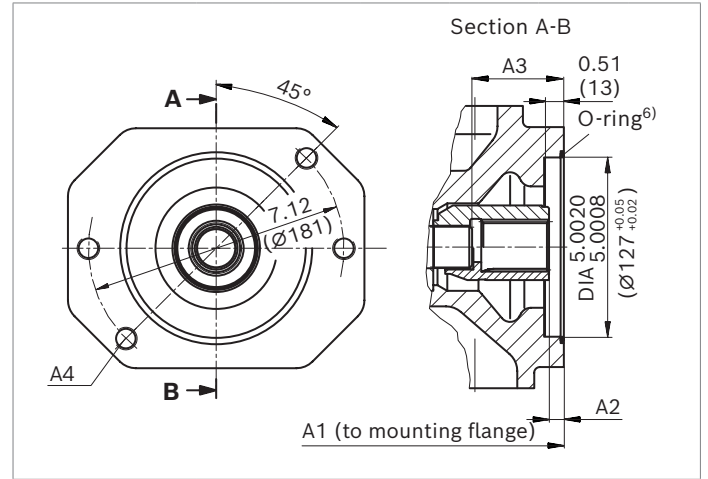

K24 (38-4 (C-C))	NG	A1	A2 ⁴⁾	A3 ⁴⁾	A4 ²⁾
	100	13.30 (338)	0.39 (10.0)	2.53 (64.3)	M16×2 ³⁾

1) According to ANSI B92.1a, 30° pressure angle, flat root, side fit, tolerance class 5
 2) Thread according to DIN 13
 3) Continuous
 4) Minimum dimensions

5) Mounting holes pattern viewed on through drive with control at top
 6) O-ring included in the scope of delivery

Overview of mounting options

SAE – mounting flange

Through drive			Mounting options – 2nd pump			
Flange ISO 3019-1	Hub for splined shaft	Code	(A)A10VSO/31 NG (shaft)	A10V(S)O/5x NG (shaft)	Gear/gerotor/vane pump	Through drive available for NG
82-2 (A)	5/8 in	K01	18 (U)	10 (U) 18 (U)	AZPF, PGH2, PGH3	18 to 100
	3/4 in	K52	18 (S, R)	10 (S) 18 (S, R)	–	18 to 100
101-2 (B)	7/8 in	K68	28 (S, R) 45 (U, W) ¹⁾	28 (S, R) 45 (U, W) ¹⁾	AZPN, AZPG	28 to 100
	1 in	K04	45 (S, R)	45 (S, R) 60, 63, 72 (U, W) ²⁾	PGH4	45 to 100
127-2 (C)	1 1/4 in	K07	71 (S, R) 88 (S, R) 100 (U) ³⁾	60, 63 (S, R) 85 (U) ³⁾ 100 (U) ³⁾	PVV BG 4, 5	71 to 100
	1 1/2 in	K24	100 (S)	85 (S) 100 (S)	PGH5	100

1) Not for main pump NG28 with K68

2) Not for main pump NG45 with K04

3) Not for main pump NG71 and NG88 with K07

Combination pumps (A)A10VSO + (A)A10VSO

By using combination pumps, it is possible to have independent circuits without the need for splitter gearboxes. When ordering combination pumps the type designations for the 1st and the 2nd pump must be joined by a "+".

Order example:

AA10VSO100DFR1/31R-VSC62K04+

AA10VSO45DFR/31R-VSC62N00

If no further pumps are to be mounted at the factory, the simple type designation is sufficient.

A tandem pump, with two pumps of equal size, is permissible without additional supports, assuming that the dynamic mass acceleration does not exceed maximum 10 g (= 98.1 m/s²).

For combination pumps consisting of more than two pumps, a calculation of the mounting flange regarding the permissible mass torque is required (please contact us).

Through drives are plugged with a **non-pressure-resistant** cover. Therefore, single pumps must be equipped with a pressure-resistant cover before commissioning. Through drives can also be ordered with a pressure-resistant cover, please specify in plain text.

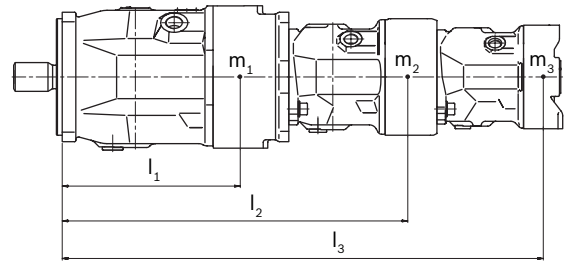

m_1, m_2, m_3	Weight of pump	[lbs (kg)]
l_1, l_2, l_3	Distance from center of gravity	[inch (mm)]
$T_m = (m_1 \times l_1 + m_2 \times l_2 + m_3 \times l_3) \times \frac{1}{12 (102)} \text{ [lb-ft (Nm)]}$		

Calculation for multiple pumps	
l_1	Front pump distance from center of gravity (values from "Permissible moments of inertia" table)
l_2	Dimension "A1" from through drive drawings (page 37 to 40) + l_1 of the 2nd pump
l_3	Dimension "A1" from through drive drawings (page 37 to 40) of the 1st pump + "A1" of the 2nd pump + l_1 of the 3rd pump

Notice

Through drives with installed hub are supplied with a spacer. The spacer must be removed before installation of the 2nd pump and before commissioning. For information, please refer to the 92711-01-B operating instructions.

Permissible moments of inertia

Size			18	28	45	71	88	100
static	T_m	lb-ft	369	649	1010	1593	1593	2213
		(Nm)	(500)	(880)	(1370)	(2160)	(2160)	(3000)
dynamic at 10 g (98.1 m/s ²)	T_m	lb-ft	37	65	101	159	159	221
		(Nm)	(50)	(88)	(137)	(216)	(216)	(300)
Weight without through drive (N00)	m	lbs	28	40	52	78	78	109
		(kg)	(12.9)	(18)	(23.5)	(35.2)	(35.2)	(49.5)
Weight with through drive (K..)	m	lbs	30	43	55	84	84	122
		(kg)	(13.8)	(19.3)	(25.1)	(38)	(38)	(55.4)
Distance, center of gravity without through drive (N00)	l_1	inch	3.62	3.94	4.45	5.00	5.00	6.34
		(mm)	(92)	(100)	(113)	(127)	(127)	(161)
Distance, center of gravity with through drive (K..)	l_1	inch	3.86	4.21	4.72	5.39	5.39	7.01
		(mm)	(98)	(107)	(120)	(137)	(137)	(178)

Connector for solenoids

Device plug on solenoid (version H) according to DIN EN 175301-803-A002M

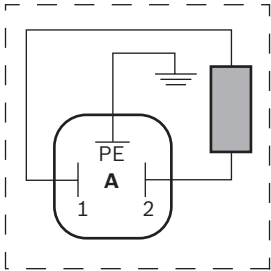

With correctly mounted mating connector, the following type of protection can be achieved:

- ▶ IP65 (DIN/EN 60529)

Notice

- ▶ If necessary, you can change the position of the connector by turning the solenoid body.
- ▶ The procedure is defined in the operating instructions 92711-01-B.

Mating connector

HIRSCHMANN **DIN EN 175301-803-A002F**
without bidirectional suppressor diode **H**

The mating connector (plug-in connector) is not included in the scope of delivery.

This can be supplied by Bosch Rexroth on request, under Bosch Rexroth material number: R902602623

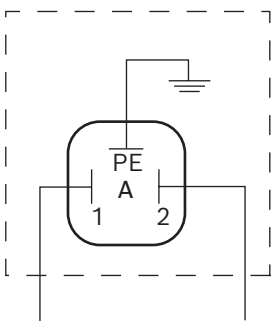

Mounting bolt M3
tightening torque:
 $M_A = 0.37 \text{ lb-ft (0.5 Nm)}$

Cable fitting M16x1.5
tightening torque:
 $M_A = 1.11 - 1.84 \text{ lb-ft (1.5 - 2.5 Nm)}$

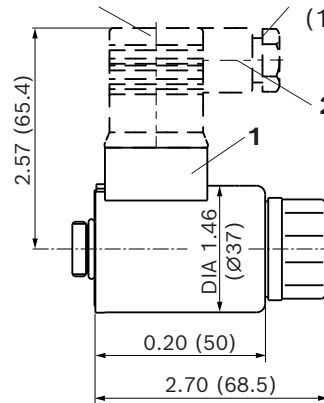

- 1 Device plug on the solenoid
- 2 Mating connector (not included in the scope of delivery)

The seal ring in the cable fitting is suitable for lines of diameter 0.18 inch to 0.39 inch (4.5 mm to 10 mm).

Control electronics

24 V nominal voltage, for ED72/ER72

Control	Electronics function	Electronics	Further information
Electric pressure control	Valve amplifier for proportional valves without electrical position feedback	VT-MSPA1	analog 30232

Installation instructions

General

The axial piston unit must be filled with hydraulic fluid and air bled during commissioning and operation. This must also be observed following a longer standstill as the axial piston unit may empty via the hydraulic lines. Particularly with the "drive shaft up" installation position, filling and air bleeding must be carried out completely as there is, for example, a danger of dry running. The leakage in the housing area must be directed to the reservoir via the highest available drain port (**L**, **L₁**). For combination pumps, the leakage must be drained off at each single pump.

If a shared drain line is used for several units, make sure that the respective case pressure in each unit is not exceeded. The shared drain line must be dimensioned to ensure that the maximum permissible case pressure of all connected units is not exceeded in any operating condition, particularly at cold start. If this is not possible, separate drain lines must be laid if necessary.

To prevent the transmission of structure-borne noise, use elastic elements to decouple all connecting lines from all vibration-capable components (e.g. reservoir, frame parts). Under all operating conditions, the suction lines and the drain lines must flow into the reservoir below the minimum fluid level. The permissible suction height h_s results from the total pressure loss. However, it must not be higher than $h_{s\ max} = 31.5$ inch (800 mm). The minimum suction pressure at port **S** must not fall below 12 psi (0.8 bar) absolute during operation and during cold start.

For the reservoir design, ensure that there is an adequate distance between the suction line and the drain line. We recommend using a baffle (baffle plate) between suction line and drain line. A baffle improves the air separation ability as it gives the hydraulic fluid more time for desorption. Apart from that, this prevents the heated return flow from being drawn directly back into the suction line. The suction port must be supplied with air-free, "calmed" and cooled hydraulic fluid.

For key, see page 45.

Installation position

See the following examples **1** to **9**.

Further installation positions are available upon request. Recommended installation position: **1** and **3**

Below-reservoir installation (standard)

Below-reservoir installation means that the axial piston unit is installed outside of the reservoir below the minimum fluid level.

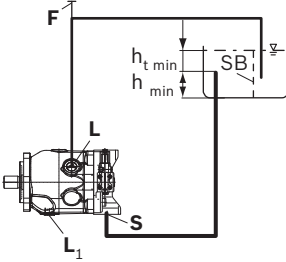
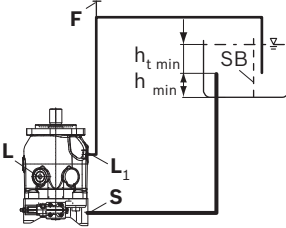
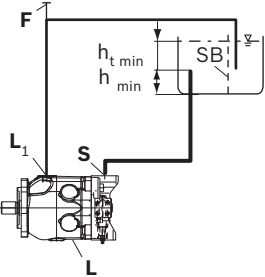
Installation position	Air bleed	Filling
1	F	L (F)
		
2¹⁾	F	L₁ (F)
		
3	F	L₁ (F)
		

¹⁾ Because complete air bleeding and filling are not possible in this position, the pump should be air bled and filled in a horizontal position before installation.

Above-reservoir installation

Above-reservoir installation means that the axial piston unit is installed above the minimum fluid level of the reservoir. To prevent the axial piston unit from draining in position 5, the height difference $h_{ES\ min}$ must be at least 0.98 inch (25 mm). Observe the maximum permissible suction height $h_{s\ max} = 31.5$ inch (800 mm)

A check valve in the drain line is only permissible in individual cases. Consult us for approval.

Installation position	Air bleed	Filling
<p>4</p>	F	L (F)
<p>5¹⁾</p>	F	L₁ (F)
<p>6</p>	F	L₁ (F)

For key, see page 45.

Inside-reservoir installation

Inside-reservoir installation is when the axial piston unit is installed in the reservoir below the minimum fluid level. The axial piston unit is completely below the hydraulic fluid. If the minimum fluid level is equal to or below the upper edge of the pump, see chapter "Above-reservoir installation".

Axial piston units with electrical components (e.g. electric control, sensors) may not be installed in a reservoir below the fluid level.

Installation position	Air bleed	Filling
<p>7</p>	Via the highest available port L	Automatically via the open port L or L₁ due to the position under the hydraulic fluid level
<p>8¹⁾</p>	Via the highest available port L₁	Automatically via the open port L , L₁ due to the position under the hydraulic fluid level
<p>9</p>	Via the highest available port L₁	Automatically via the open port L or L₁ due to the position under the hydraulic fluid level

¹⁾ Because complete air bleeding and filling are not possible in this position, the pump should be air bled and filled in a horizontal position before installation.

Key	
F	Filling / Air bleeding
S	Suction port
L; L₁	Drain port
SB	Baffle (baffle plate)
$h_{t\ min}$	Minimum required immersion depth (7.87 inch (200 mm))
h_{min}	Minimum required distance to reservoir bottom (3.94 inch (100 mm))
$h_{ES\ min}$	Minimum height required to prevent axial piston unit from draining (0.98 inch (25 mm))
$h_{S\ max}$	Maximum permissible suction height (31.5 inch (800 mm))

Notice

Port **F** is part of the external piping and must be provided on the customer side to simplify the filling and air bleeding.

Project planning notes

- ▶ The (A)A10VSO axial piston variable pump is intended to be used in open circuit.
- ▶ Project planning, installation and commissioning of the axial piston units requires the involvement of skilled personnel.
- ▶ Before using the axial piston unit, please read the corresponding instruction manual completely and thoroughly. If necessary, this can be requested from Bosch Rexroth.
- ▶ Before finalizing your design, request a binding installation drawing.
- ▶ The specified data and notes contained herein must be observed.
- ▶ Depending on the operating conditions of the axial piston unit (working pressure, fluid temperature), the characteristic curve may shift.
- ▶ The characteristic curve may also shift due to the dither frequency or control electronics.
- ▶ Preservation: Our axial piston units are supplied as standard with preservation protection for a maximum of 12 months. If longer preservation protection is required (maximum 24 months), please specify this in plain text when placing your order. The preservation periods apply under optimal storage conditions, details of which can be found in the data sheet 90312 or the instruction manual.
- ▶ Not all versions of the product are approved for use in a safety function according to ISO 13849. Please consult the proper contact at Bosch Rexroth if you require reliability parameters (e.g. $MTTF_d$) for functional safety.
- ▶ Depending on the type of control used, electromagnetic effects can be produced when using solenoids. Applying a direct voltage signal (DC) to solenoids does not create electromagnetic interference (EMI) nor is the solenoid affected by EMI. Electromagnetic interference (EMI) potential exists when operating and controlling a solenoid with a modulated direct voltage signal (e.g. PWM signal) Appropriate testing and measures should be taken by the machine manufacturer to ensure other components or operators (e.g. with pacemaker) are not affected by this potential.
- ▶ Pressure controllers are not safeguards against pressure overload. Be sure to add a pressure relief valve to the hydraulic system.
- ▶ Please note that a hydraulic system is an oscillating system. This can lead, for example, to the excitation of the natural frequency within the hydraulic system during operation at constant rotational speed over a long period of time. The excitation frequency of the pump is 9 times the rotational speed frequency. This can be prevented, for example, with suitably designed hydraulic lines.
- ▶ Please note the details regarding the tightening torques of port threads and other threaded joints in the instruction manual.
- ▶ The ports and fastening threads are designed for the p_{max} permissible pressures of the respective ports, see the connection tables. The machine or system manufacturer must ensure that the connecting elements and lines correspond to the specified application conditions (pressure, flow, hydraulic fluid, temperature) with the necessary safety factors.
- ▶ The service ports and function ports are only intended to accommodate hydraulic lines.

Safety instructions

- ▶ During and shortly after operation, there is a risk of getting burnt on the axial piston unit and especially on the solenoids. Take the appropriate safety measures (e.g. by wearing protective clothing).
- ▶ Moving parts in control equipment (e.g. valve spools) can, under certain circumstances, get stuck in position as a result of contamination (e.g. contaminated hydraulic fluid, abrasion, or residual dirt from components). As a result, the hydraulic fluid flow and the build-up of torque in the axial piston unit can no longer respond correctly to the operator's specifications. Even the use of various filter elements (external or internal flow filtration) will not rule out a fault but merely reduce the risk. The machine/system manufacturer should test whether additional measures are required on the machine for the relevant application in order to bring the driven consumer into a safe position (e.g. safe stop) and make sure any measures are properly implemented.

Bosch Rexroth Corporation
8 Southchase Court
Fountain Inn, SC 29644-9018
USA
Telephone (864) 967-2777
Facsimile (864) 962-5338
www.boschrexroth-us.com

Bosch Rexroth Corporation
2315 City Line Road
Bethlehem, PA 18017-2131,
USA
Telephone (610) 694-8300
Facsimile (610) 694-8467
www.boschrexroth-us.com

© Bosch Rexroth Corporation 2021. All rights reserved, also regarding any disposal, exploitation, reproduction, editing, distribution, as well as in the event of applications for industrial property rights. The data specified within only serves to describe the product. No statements concerning a certain condition or suitability for a certain application can be derived from our information. The information given does not release the user from the obligation of own judgment and verification. It must be remembered that our products are subject to a natural process of wear and aging.