

Pressure reducing valve, direct operated

Type ZDR



- ▶ Nominal size 10
- ▶ Component series 5X
- ▶ Maximum operating pressure 350 bar
- ▶ Maximum flow 160 l/min

Features

- ▶ Sandwich plate valve
- ▶ Porting pattern according to ISO 4401-05-04-0-05
- ▶ 4 pressure ratings
- ▶ 4 adjustment types, optionally:
 - Rotary knob
 - Sleeve with hexagon and protective cap
 - Lockable rotary knob with scale
 - Rotary knob with scale
- ▶ Check valve, optional (version "A")
- ▶ Pressure reduction in channel A, B or channel P
- ▶ Corrosion-protected design

Contents

Features	1
Ordering code	2
Symbols	3
Function, section	4
Technical data	5, 6
Characteristic curves	7
Dimensions	8, 9
Further information	10

Ordering code

01	02	03	04	05	06	07	08	09	10	11	12	13
Z	DR	10	D			-	5X	/		Y		

01	Sandwich plate valve	Z
02	Pressure reducing valve	DR
03	Size 10	10
04	Direct operated	D
05	Pressure reduction in channel A②	A ◇
	Pressure reduction in channel P① (pilot oil supply from channel B)	B
	Pressure reduction in channel P①	P ◇

Adjustment type

06	Rotary knob	1
	Sleeve with hexagon and protective cap ("J3" version without protective cap)	2 ◇
	Lockable rotary knob with scale	3 ¹⁾
	Rotary knob with scale	7
07	Component series 50 ... 59 (50 ... 59: unchanged installation and connection dimensions)	5X

Maximum secondary pressure

08	25 bar	25
	75 bar	75 ◇
	150 bar	150 ◇
	210 bar	210 ◇
	315 bar (only version "B" and "P")	315 ◇
09	Pilot oil supply internal, pilot oil return external	Y
10	With check valve (only version "A")	no code
	Without check valve	M ◇

Corrosion resistance

11	None	no code ◇
	Improved corrosion protection (240 h salt spray test according to EN ISO 9227); (only version "1" and "2")	J3

Seal material (observe compatibility of seals with hydraulic fluid used, see page 6)

12	NBR seals	no code ◇
	FKM seals	V

Connection thread

13	Pipe thread according to ISO 228/1	no code ◇
	SAE thread	/12

¹⁾ H-key with material no. **R900008158** is included in the scope of delivery.



Notice:

To port X and Y bored according to ISO 4401-05-05-0-05 (e.g. for pilot-operated directional valve NG10), version "SO30" applies at the end of the ordering code.



Notice: ◇ = Preferred type

Symbols (① = component side, ② = plate side)

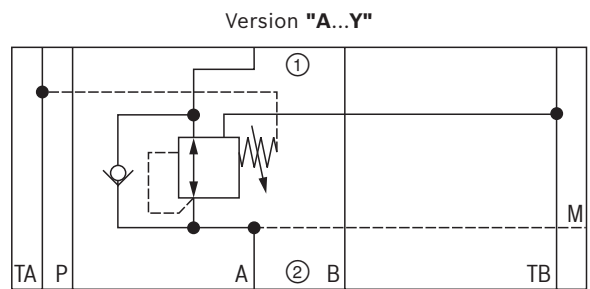
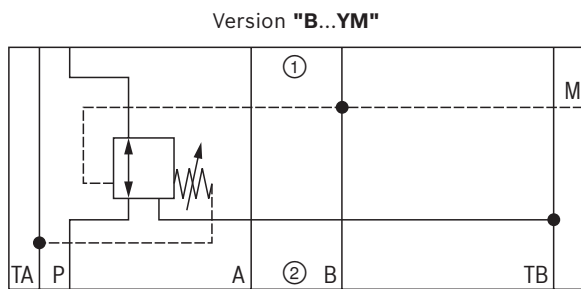
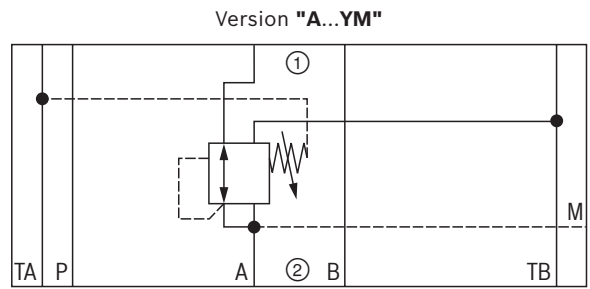
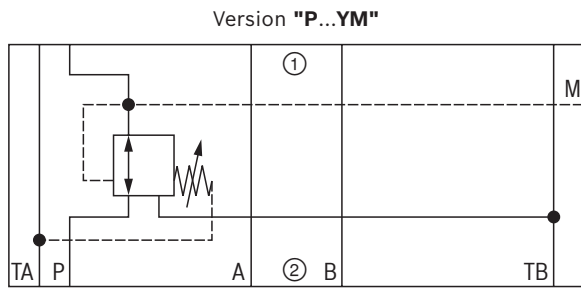

Notice:

Deviating from ISO 4401, port T is in this data sheet called TA, port T1 is called TB.

Function, section

The valve type ZDR is a direct operated pressure reducing valve in sandwich plate design with pressure limitation of the secondary circuit. It is used to reduce the system pressure.

The pressure reducing valve basically comprises housing (1), control spool (2), compression spring (3), adjustment type (4) and an optional check valve.

The secondary pressure is set via the adjustment type (4).

Version "A"

The valve is open in initial position. Hydraulic fluid can flow from channel A① to channel A② without restrictions. The pressure in channel A② is simultaneously applied via the control line (5) at the piston area opposite the compression spring (3). If the pressure in channel A② exceeds the value set at the compression spring (3), the control spool (2) is pushed against the compression spring (3) to control position and keeps the set pressure in channel A② at a constant level.

Control signal and pilot oil are supplied internally via the control line (5) from channel A②.

If the pressure in channel A② increases further due to an external force effect at the actuator, it pushes the

control spool (2) even further against the compression spring (3).

In this way, channel A② is connected to the tank via the control edge (6) at the control spool (2) and the housing (1). So much hydraulic fluid is discharged into the tank that the pressure does not increase any further.

The leakage oil drain from the spring chamber (7) is always effected externally via channel TA.

A measuring port (8) allows for the control of the secondary pressure at the valve.

A check valve can be used for free flow back from channel A② to A① with version "A".

Versions "P" and "B".

With version "P", the pressure reduction is effected in channel P①. Control signal and pilot oil are supplied internally from channel P①.

With version "B", the pressure is reduced in channel P①; but the pilot oil is extracted from channel B.

If the directional valve is in spool position P to A, the pressure in channel B may not exceed the set secondary pressure. Otherwise, there is pressure reduction in channel A.

Notice:

If used without directional valve, channels TA and TB are connected to each other (e. g. in the cover plate). During set-up of a directional seat valve NG10, a sandwich plate type HSZ10A078-3X/M00 (material no. R900537264) has to be used.

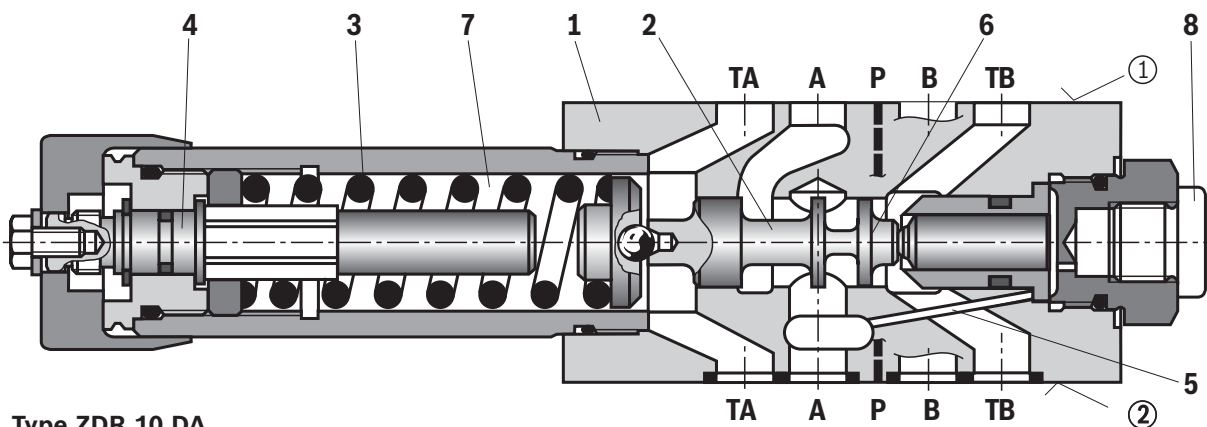

Type ZDR 10 DA ...

① = component side

② = plate side

Technical data

(For applications outside these values, please consult us!)

General	
Type of connection	Subplate mounting
Porting pattern	ISO 4401-05-04-0-05
Weight	kg 2.8
Installation position	Any
Ambient temperature range	°C -20 ... +80 (NBR seals) -15 ... +80 (FKM seals)
Conformity	► RoHS directive 2015/65/EU ¹⁾

Hydraulic			
Maximum operating pressure	► Input		
	- Version "B", "P"	bar	350
	- Version "A"	bar	315
	► Output	bar	25; 75; 150; 210; 315 ²⁾
Hydraulic fluid			See table below
Hydraulic fluid temperature range	°C		-20 ... +80 (NBR seals) -15 ... +80 (FKM seals)
Viscosity range	mm ² /s		10 ... 800
Maximum admissible degree of contamination of the hydraulic fluid, cleanliness class according to ISO 4406 (c)			Class 20/18/15 ³⁾
Maximum flow	► Version "B", "P"	l/min	160
	► Version "A"	l/min	80
Maximum counter pressure	► Port T	bar	160

¹⁾ The product fulfills the substance requirements of the RoHS directive 2015/65/EU.

²⁾ Only version "B" and "P"

³⁾ The cleanliness classes specified for the components must be adhered to in hydraulic systems. Effective filtration prevents faults and at the same time increases the life cycle of the components.

Technical data

(For applications outside these values, please consult us!)

Hydraulic fluid	Classification	Suitable sealing materials	Standards	Data sheet	
Mineral oils	HL, HLP	NBR, FKM	DIN 51524	90220	
Bio-degradable	▶ Insoluble in water	HETG	ISO 15380	90221	
		HEES			
	▶ Soluble in water	HEPG	ISO 15380		
Flame-resistant	▶ Water-free	HFDU (glycol base)	ISO 12922	90222	
		HFDU (ester base)			
		HFDR			
	▶ Containing water	HFC (Fuchs: Hydrotherm 46M, Fuchs Renosafe 500; Petrofer: Ultra Safe 620; Houghton: Safe 620; Union: Carbide HP5046)	NBR	ISO 12922	90223

**Important information on hydraulic fluids:**

- ▶ For further information and data on the use of other hydraulic fluids, please refer to the data sheets above or contact us.
- ▶ There may be limitations regarding the technical valve data (temperature, pressure range, life cycle, maintenance intervals, etc.).
- ▶ The ignition temperature of the hydraulic fluid used must be 50 K higher than the maximum surface temperature.
- ▶ Bio-degradable and flame-resistant – containing water: If components with galvanic zinc coating (e.g. version "J3" or "J5") or parts containing zinc are used, small amounts of dissolved zinc may get into the hydraulic system and cause accelerated aging of the hydraulic fluid. Zinc soap may form as a chemical reaction product, which may clog filters, nozzles and solenoid valves – particularly in connection with local heat input.

▶ Flame-resistant – containing water:

Due to the increased cavitation tendency with HFC hydraulic fluids, the life cycle of the component may be reduced by up to 30% as compared to the use with mineral oil HLP. In order to reduce the cavitation effect, it is recommended – if possible specific to the installation – backing up the return flow pressure in ports T to approx. 20% of the pressure differential at the component.

Characteristic curves

(measured with HLP46, $\vartheta_{oil} = 40 \pm 5 \text{ }^\circ\text{C}$)

$p_A \cdot q_V$ characteristic curves – Version "A"

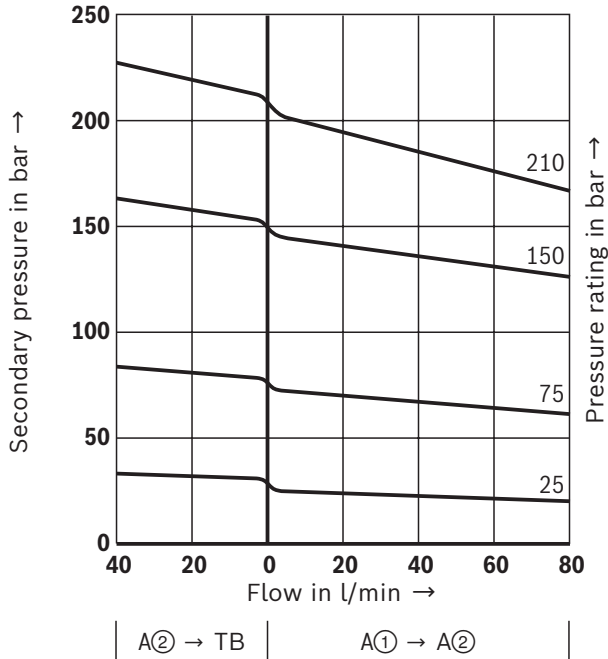

$p_A \cdot q_V$ characteristic curves – Version "B" and "P"

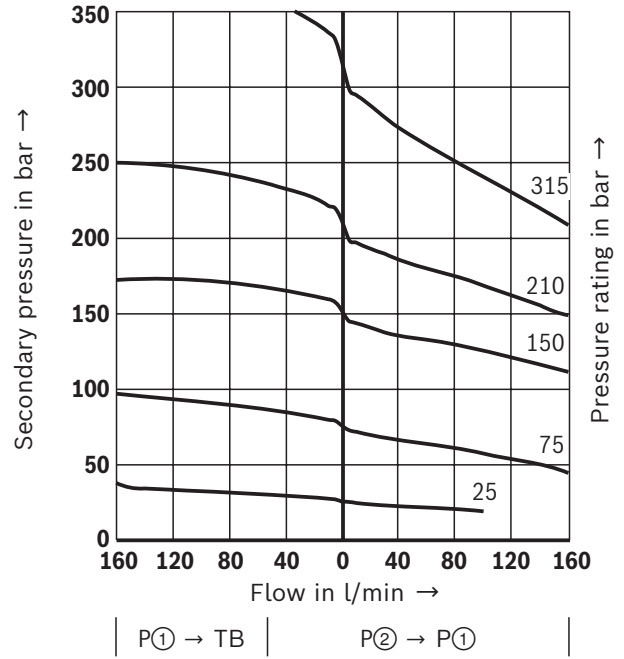

$\Delta p_{min} \cdot q_V$ characteristic curves – Version "A"

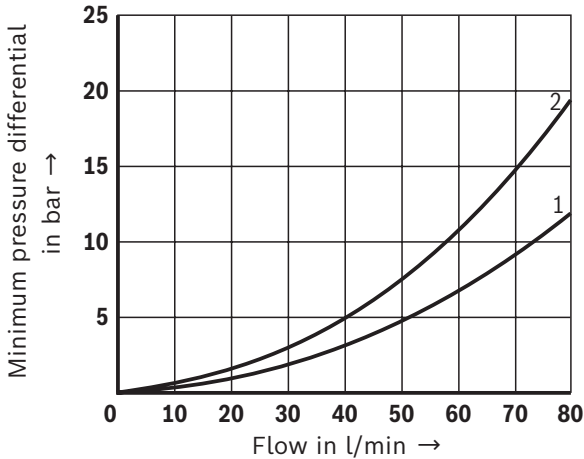

$\Delta p_{min} \cdot q_V$ characteristic curves – Version "B" and "P"

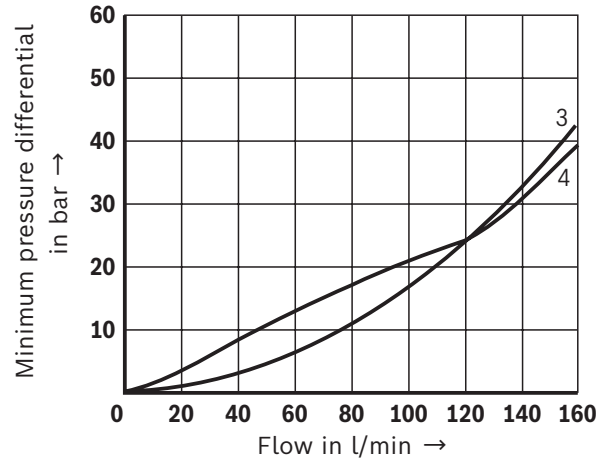

$\Delta p \cdot q_V$ characteristic curves – Version "A"

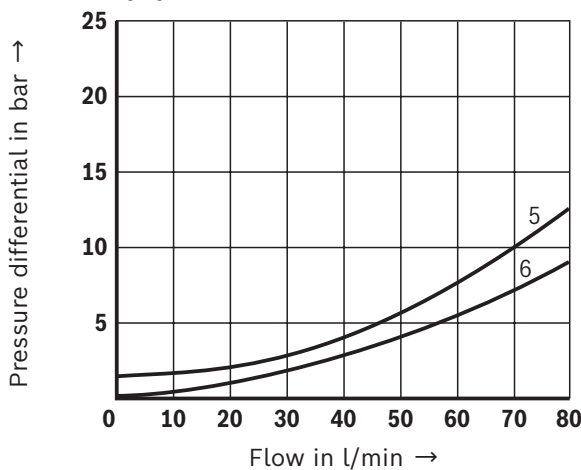

- 1 A① → A②
- 2 A② → TB (3rd way; version "210")
- 3 P② → P①
- 4 P① → TB (3rd way; version "210")
- 5 A② → A①; flow only via check valve
- 6 A② → A①; flow via check valve and fully opened control cross-section

Notes:

- ▶ Typical characteristic curves which are subject to tolerance variations.
- ▶ The curve development is maintained if the pressure is set lower according to the pressure rating.
- ▶ The characteristic curves apply for output pressure $p_T = 0 \text{ bar}$ in the entire flow range.

Dimensions
(dimensions in mm)

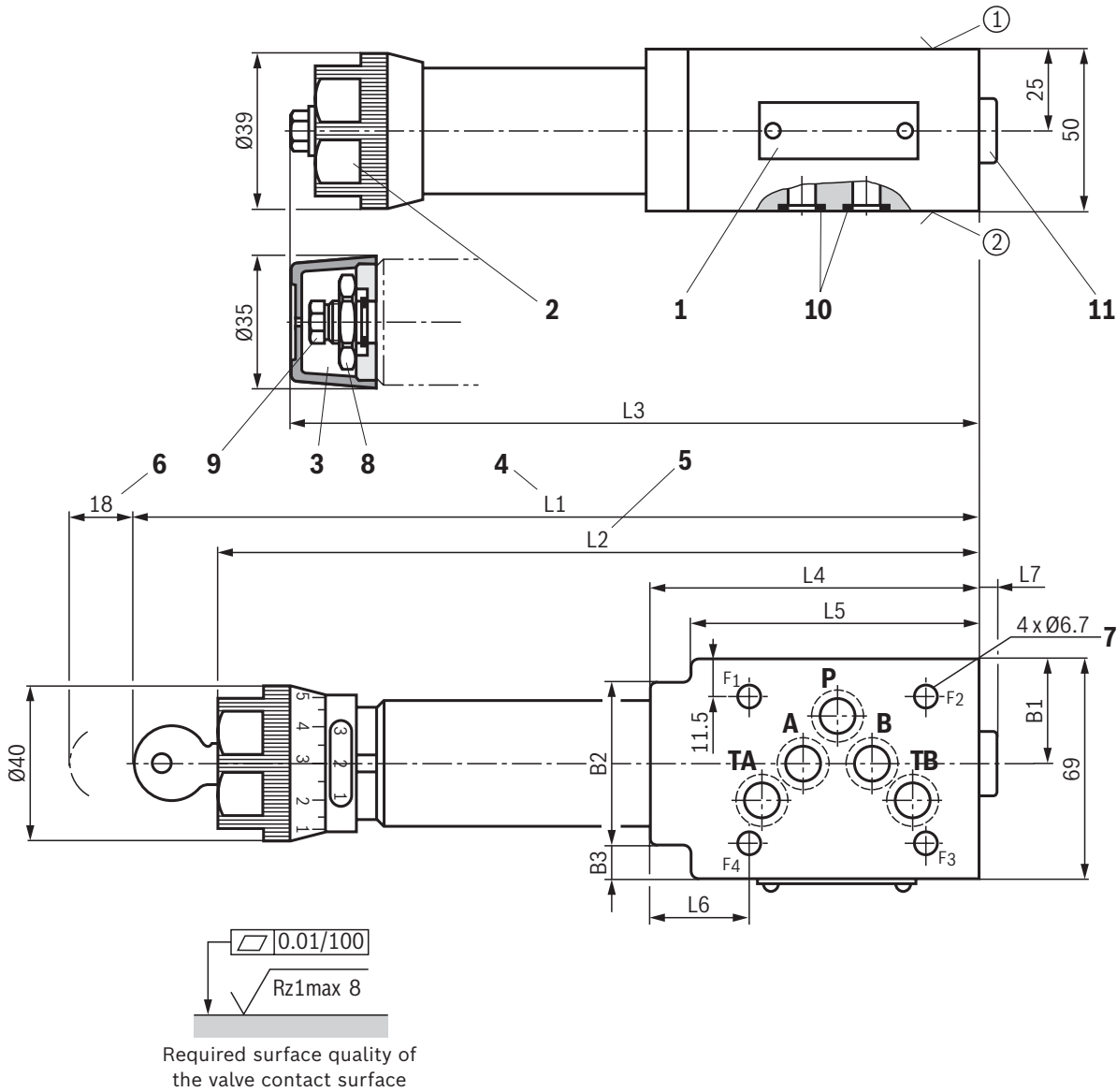

Version	L1	L2	L3	L4	L5	L6	L7 ¹⁾	B1	B2	B3	Measuring port ¹⁾	
											Internal hexagon	Tightening torque M_A in Nm
"A"	254	230	210	104	93	31.5	4	32.9	51	12	SW6	23 ±10%
"B", "P"	242	218	198	93	-	18.5	15	35	-	-	SW6	23 ±10%

1) Deviating dimensions for version "12"

Version	L7	Measuring port	
		Internal hexagon	Tightening torque M_A in Nm
"A"	1.7	3/16"	23 ±10%
"B", "P"	12.7	3/16"	23 ±10%

Notice:

- ▶ To port X and Y bored according to ISO 4401-05-05-0-05 (e.g. for pilot-operated directional valve NG10), version "SO30" applies at the end of the ordering code.
- ▶ The dimensions are nominal dimensions which are subject to tolerances.

Item explanations and valve mounting screws

see page 9.

Dimensions

- ① component side – Porting pattern according to ISO 4401-05-04-0-05
 - ② plate side – Porting pattern according to ISO 4401-05-04-0-05
-
- 1 Name plate
 - 2 Adjustment type "1"
 - 3 Adjustment type "2"
 - 4 Adjustment type "3"
 - 5 Adjustment type "7"
 - 6 Space required to remove the key
 - 7 Valve mounting bores
 - 8 Lock nut, wrench size 24
 - 9 Hexagon, wrench size 10
 - 10 Identical seal rings for ports A, B, P, TA, TB
 - 11 Measuring port; hold the reducing piece SW24 in place when loosening the plug screw.

Valve mounting screws (separate order)

4 hexagon socket head cap screws ISO 4762 - M6 - 10.9



Notice:

Length and tightening torque of the valve mounting screws must be calculated according to the components mounted under and over the sandwich plate valve.

Further information

- ▶ Hydraulic valves for industrial applications
 - ▶ Subplates
 - ▶ Hydraulic fluids on mineral oil basis
 - ▶ Environmentally compatible hydraulic fluids
 - ▶ Flame-resistant, water-free hydraulic fluids
 - ▶ Flame-resistant hydraulic fluids – containing water (HFAE, HFAS, HFB, HFC)
 - ▶ Use of non-electrical hydraulic components in an explosive environment (ATEX)
 - ▶ Information on available spares
- Operating instructions
07600-B
- Data sheet 45100
- Data sheet 90220
- Data sheet 90221
- Data sheet 90222
- Data sheet 90223
- Data sheet 07011
- www.boschrexroth.com/spc

Notes

Notes

Bosch Rexroth AG
Industrial Hydraulics
Zum Eisengießer 1
97816 Lohr am Main, Germany
Phone +49 (0) 93 52/40 30 20
my.support@boschrexroth.de
www.boschrexroth.de

© All rights reserved to Bosch Rexroth AG, also regarding any disposal, exploitation, reproduction, editing, distribution, as well as in the event of applications for industrial property rights.
The data specified above only serve to describe the product. No statements concerning a certain condition or suitability for a certain application can be derived from our information. The information given does not release the user from the obligation of own judgment and verification.
It must be remembered that our products are subject to a natural process of wear and aging.